

## Computing Output Voltage Given Input Deflection or Load

### Deflection (see Figure 4)<sup>1,2</sup>

$$E_0 = E_{in}C(1 + x)y \text{ (U.S. units)}$$

$$E_0 = E_{in}C(2.54 + x)y \text{ (metric units)}$$

where:

$E_0$  = total change in output voltage (volts)

$E_{in}$  = excitation voltage applied to DS (volts)

$C$  = constant scale factor for a DS-6

= 6.6 V/V·in<sup>2</sup> (U.S. units) or 1.023 V/V·cm<sup>2</sup> (metric units)

$x$  = distance along DS to where deflection is being measured (in. or cm)

$y$  = input deflection (in. or cm) ( $y_{max} = \pm 0.012'' (\pm 0.030 \text{ cm})$ )

### Example

$$E_{in} = 12 \text{ volts} \quad C = 6.6 \text{ V/V} \cdot \text{in}^2 \text{ (U.S. units)} \quad X = 0 \quad y = 0.001''$$

$$E_0 = E_{in}C(1 + x)y = 12 \text{ volts} (6.6 \text{ V/V} \cdot \text{in}^2) (1 + 0'')(0.001'')$$

$$= 0.0792 \text{ volts} = 79.2 \text{ mV for a } 0.001''$$

deflection

### Load (see Figure 5)<sup>1,2</sup>

$$E_0 = E_{in}D(1 - x)F \text{ (U.S. units)}$$

$$E_0 = E_{in}D(2.54 - x)F \text{ (metric units)}$$

where:

$E_0$  = total change in output voltage (volts)

$E_{in}$  = excitation voltage applied to DS (volts)

$D$  = constant scale factor for a DS-6

= 0.132 V/V·lb·in (U.S. units) or 0.1142 V/V·kg·cm (metric units)

$x$  = distance along DS to where load is applied (in. or cm)

$F$  = input load (lb or kg)

### Example

$$E_{in} = 12 \text{ volts} \quad D = 0.1142 \text{ V/V} \cdot \text{kg} \cdot \text{cm} \text{ (metric units)}$$

$$x = 0 \text{ cm} \quad F = 1 \text{ gram} = 0.001 \text{ kg}$$

$$E_0 = E_{in}D(2.54 - x)F = 12 \text{ volts} (0.1142 \text{ V/V} \cdot \text{kg} \cdot \text{cm}) (2.54 - 0 \text{ cm})(0.001 \text{ kg})$$

$$= 0.003481 \text{ volts} = 3.481 \text{ mV for a } 1 \text{ gram load}$$

### Notes:

<sup>1</sup> At full scale,  $E_0/E_{in}$  should not exceed 100 mV/V at  $x = 0$ .

<sup>2</sup>  $E_{in}$  should not allow more than 50 mA per half bridge.

Example: 2000 ohm gage can take 100 VDC (2000 ohms/100 VDC = 0.050 amps = 50 mA).

Recommended operating voltage: 0-30 VDC/gage.

### Mechanical Stiffness

$$K = 50(1 + x) / (1 - x) \text{ (U.S. units --- lb/in.)}$$

$$K = 8.94(2.54 + x) / (2.54 - x) \text{ (metric units --- kg/cm)}$$

DS products are covered by one or more of the following patents:

3,687,755; 3,685,110; 3,742,418; or 3,832,898.

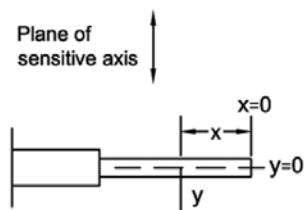

Figure 4. Displacement Input

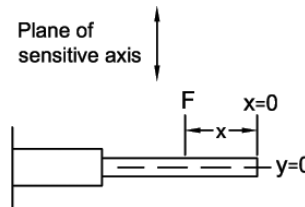

Figure 5. Force Input



**KM KISTLER-MORSE**  
Measure of Success

## Displacement Sensor (DS-6) Inspection and Operation Instructions

### CAUTION

**Do not exceed 0.012" (0.03cm) deflection.** Any additional deflection will cause permanent damage. Do not apply excessive torque to the DS beam. This will also cause permanent damage.

### Specifications

Output	100 mV/V/0.012" (100 mV/V/0.03cm)
Gradient	(6.6 mV ± 0.6 mV)/V/0.001"
Maximum Deflection	0.012" (0.30mm)
Operating Temperature	-100° F to +450° F (-73° C to +232° C)
Linearity	0.1% full scale
Repeatability	0.01% full scale
Hysteresis	Less than 0.01% full scale
Thermal Stability	0.03%/°F/0.012" (0.054%/°C/0.03cm) <sup>1</sup>
Gradient Stability	0.01%/°F/0.012" (0.054%/°C/0.03cm)
Humidity	Tested as 95% RH, 140° F (60° C), 100 hours
Materials	Beam, 17-4PH stainless steel
Current Maximum	50 mA (half bridge)
Dual Axis Units	2 half bridges (2 gages per axis) 90° apart ± 2°
Gage Resistance	All values nominal, gages matched within 10%
Spring Rate	0.02 in./lb (0.11 cm/kg), nominal

### Notes:

<sup>1</sup>DS can be temperature compensated to bring the thermal stability limit tighter.



150 Venture Boulevard  
Spartanburg, Sc 29306 USA

**1.800.426.9010**

tel: 864.574.2763

fax: 864.574.8063

kistlermorse.com

# Unpacking and Inspection

- Remove each DS from the shipping container and visually inspect for damage that may have occurred during shipment. Note damage on the shipping receipt and report it to the carrier and to K-M.
- Review the data in the Factory Data Table below and verify that each unit is in the configuration ordered.
- Perform a functional check of each DS before installation to verify that it has not been damaged during shipment.
  - Carefully remove DS from the vial. **Do not twist or pry.** Do not twist white RTV rubber. The leads are encased for protection. Twisting or squeezing it could damage the leads.
  - Attach test leads to the non-insulated portion of the DS leads. Test the resistance. Verify that the resistance is within  $\pm 10\%$  of the stated resistance in the Factory Data Table below.

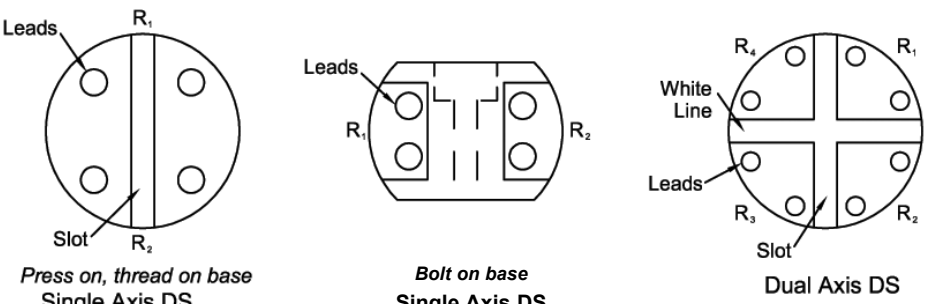
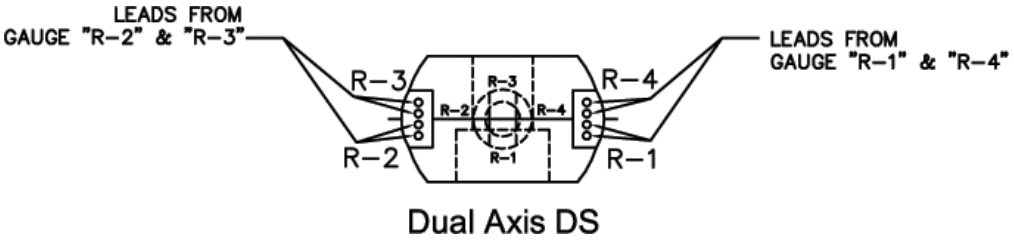

Figure 1. Base Options



Dual Axis DS

## Factory Data Table

Date Recorded: \_\_\_\_\_

Part No. (DS-)	Serial No.	mV/V/0.001"	Measured Resistance			
			R <sub>1</sub>	R <sub>2</sub>	R <sub>3</sub>	R <sub>4</sub>

# Electrical Connection

Each axis is independent and should be connected separately. However, each axis is bi-directional and will give full output for either direction from zero.

The DS meets all specifications when connected in a circuit. Evaluation of resistance changes alone are an insufficient test of performance.

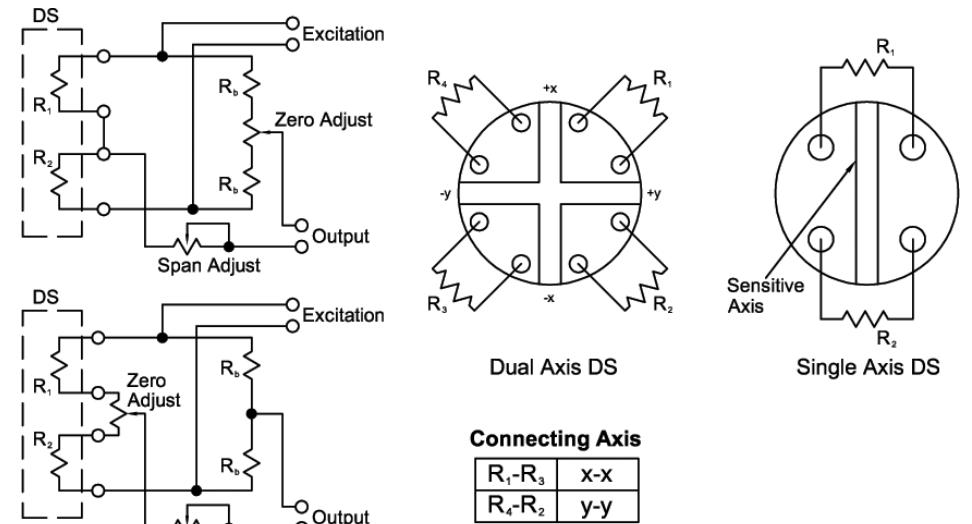

Figure 2. Wiring Schematics

**Connecting Axis**

R <sub>1</sub> -R <sub>3</sub>	x-x
R <sub>4</sub> -R <sub>2</sub>	y-y

# Use of DS

Sensitive axis is aligned with slot at base of unit or bolt-through hole. Sensitivity is highest at this point. To reduce sensitivity, rotate DS slightly off axis (so input deflection is not in line with slot) and output will decrease.

## CAUTION

**Do not exceed 0.012" (0.03cm) deflection.** Any additional deflection will cause permanent damage. Do not apply excessive torque to the DS beam. This will also cause permanent damage.

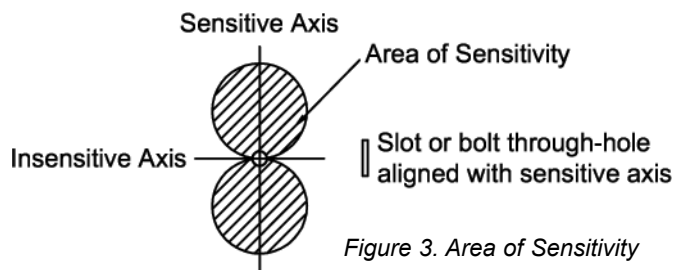

Figure 3. Area of Sensitivity