

STXplus Signal Transmitter Installation and Operation Manual

CAUTION

It is essential that all instructions in this manual be followed precisely to ensure proper operation of the equipment.



KM **KISTLER-MORSE**
Measure of Success

97-1180-01
Revision F
October 2011

NOTICE

The content of this document is the intellectual property of Kistler-Morse®. Any reproduction or translation of this document without the written authorization of Kistler-Morse® is strictly prohibited.

CAUTION

Follow these rules if welding is done on the vessel after installation of Kistler-Morse® sensors/transducers. The electrical current of the welder may pass through the sensor/transducer, causing damage to it and possibly to the signal processor. To avoid damage, follow these precautions:

1. Disconnect the sensor/transducer cables from the signal processor.
2. Ground the welder as close to the welding joint as possible. The welding ground must be between the sensor/transducer and the weld joint to prevent the welding current from going through the sensor/transducer to earth ground.

NOTE

High temperatures can damage sensors/transducers. If you are welding in the vicinity of a sensor/transducer, monitor the temperature of the metal adjacent to the sensor/transducer. If it becomes too hot to touch, stop welding immediately and remove the sensor/transducer before continuing. Prior to reinstalling the sensor/transducer, verify that no damage has occurred.

This manual reflects STXplus Software Revision B. If you have a previous revision, please contact Kistler-Morse®.

TABLE OF CONTENTS

CHAPTER 1: INTRODUCTION	1-1
Introduction	1-1
Physical Description	1-1
Functional Description	1-1
Analog Mode	1-1
Filters	1-1
LEDs	1-1
Manual Conventions	1-1
CHAPTER 2: HARDWARE INSTALLATION	2-1
General Information	2-1
Unpacking and Inspection	2-1
Mounting STXplus	2-1
Stand-Alone STXplus with Customer-Supplied Panel/Enclosure	2-1
Stand-Alone STXplus with Kistler-Morse® Supplied Enclosure	2-1
Drilling Holes in the Enclosure	2-1
Wiring System	2-2
Wiring Junction Box to STXplus	2-2
Wiring Power	2-2
Wiring Current Output	2-2
External Current Loop Power Supply	2-2
Sealing Openings in Stand-Alone STXplus Enclosure	2-2
Quick Reference	2-3
Default	2-3
Changing the Modbus or Serial Port Address	2-3
Changing from Half-Bridge 3-Wire to Full-Bridge 4-Wire	2-3
Enabling Remote Sense	2-3
Enabling Remote Loop Voltage for the 0-20mA/4-20mA	2-3
Enabling the Modbus 5.11k Ω Pull-Up Resistor and the 12k Ω End-Of-Line Resistor	2-4
Changing from RS-422 to RS-485	2-4
4-20mA Output	2-4
CHAPTER 3: STAND-ALONE ANALOG CALIBRATION AND SET UP	3-1
Introduction	3-1
Trimming the Current Output	3-1
Trim the 0mA Current Output	3-1
Trim the 4mA Current Output	3-1
Trim the 20mA Current Output	3-1
Setting Up Current Output Operating Mode (0-20mA or 4-20mA)	3-2
Setting Up Input Voltage Range	3-2
Setting Up Channel Enable	3-2
Analog Calibration	3-3
High-Accuracy Calibration	3-3
Starting with an Empty Vessel	3-3
Starting with a Full Vessel	3-4
Calibration by Adding a Known Quantity of Material	3-5
Calibration by Subtracting a Known Quantity of Material	3-5

System Set Up	3-6
Descriptions	3-6
Current Output Range	3-6
Current Output Tracking	3-6
Current Output Fail-safe	3-6
LO Span and HI Span	3-6
0mA, 4mA, and 20mA Trim	3-6
Serial Port 1 Baud Rate/Protocol	3-6
Averaging Factor	3-6
DSP Filter	3-7
DSP Enable	3-7
DSP Step	3-7
Input Voltage Range	3-7
Modbus Baud Rate	3-7
Channel Enable	3-7
Tare	3-8

APPENDIX A: PRODUCT SPECIFICATIONS **A-1**

APPENDIX B: KISTLER-MORSE® PROTOCOL SERIAL COMMANDS **B-1**

Introduction	B-1
Command Table	B-1
Checksum Calculation	B-4
Examples	B-5

APPENDIX C: MODBUS PROTOCOL SERIAL COMMANDS **C-1**

Introduction	C-1
Modbus Implementation	C-1
Modbus Function Codes	C-3
Modbus Exception Responses	C-5
Commands	C-6
Important Points	C-7
Modbus Memory Map Table	C-8

APPENDIX D: TECHNICAL DRAWINGS **D-1**

TI-SP.STXP-01	D-2
TI-SP.STXP-02	D-3
TI-STXPlus.Varistor	D-8

CHAPTER 1: INTRODUCTION



INTRODUCTION

The STXplus Signal Transmitter, shown above, is a 4-channel signal processor that receives an analog input from strain gage sensors/transducers and provides 2-5A output relays, current, and serial output. The STXplus has a 23-bit analog-to-digital (A/D) converter that provides high resolution.

PHYSICAL DESCRIPTION

The STXplus PCB can be configured in several ways:

- 1. STXplus in Kister-Morse[®] Supplied Enclosure.** The STXplus PCB is housed in a NEMA-rated enclosure and wall-mounted near the vessel. An optional AC power supply can be purchased, or customer-supplied DC power can be used.
- 2. STXplus in a Customer-Supplied Panel/Enclosure.** An optional AC power supply can be purchased, or customer-supplied DC power can be used.

FUNCTIONAL DESCRIPTION

Analog Mode

The STXplus can receive an analog signal from either half-bridge sensors/transducers

(Load Cell, Microcell, Load Stand II, and Load Disc II) or from full-bridge sensors/transducers.

The analog engine is calibrated using the calibration buttons. When in Analog Mode, current output from the STXplus PCB is controlled by the analog engine.

Filters

The STXplus has several features which help provide stable output. The Sentry™ DSP Filter reduces output changes that can result from vibration.

LEDs

Com 1 LEDs	TXD2, RXD2
Modbus LEDs	TXD1, RXD1
15V	D3
5V Isolation for Current Output	D29
Programming Parameter	D15-D18
Programming Value	D19-D22
Relay 1	D13
Relay 2	D11
4-20mA Current Output	D30
5V Analog Voltage	D26

Manual Conventions

WARNING!

Possible danger to people. Injury may result if this information is ignored.

CAUTION

Possible risk to the product. The signal processor or other equipment may be damaged if this information is ignored.

NOTE

Contains additional information about a step or feature critical to the installation or operation of the signal processor.

CHAPTER 2: HARDWARE INSTALLATION

GENERAL INFORMATION

This chapter provides instructions on how to install and wire the STXplus. The STXplus can be installed in several ways.

Refer to the drawings in Appendix D for wiring and installation details.

WARNING!

To prevent equipment damage or personal injury, once the STXplus has been connected to power:

- 1. Disconnect power before wiring anything to the STXplus, adding or removing PCBs, or mounting the stand-alone STXplus.**
- 2. Deactivate power to the controlled devices.**

Review all instructions before beginning installation. Follow all instructions carefully to ensure the equipment is properly mounted and wired.

UNPACKING AND INSPECTION

Carefully remove the STXplus from the shipping container and place it on a flat surface. Visually inspect for damage that may have occurred during shipment. If any damage is evident, note it on the shipping receipt. Report the damage to the carrier and to a Kistler-Morse® representative immediately. Store the shipping container and packing material for later use in the event the equipment must be returned to the factory.

MOUNTING THE STXPLUS

Do not mount the STXplus near high power equipment, contactors, SCR drives, 440V lines, etc. Refer to Appendix A for

environmental specifications before mounting.

Stand-Alone STXplus with Customer-Supplied Panel/Enclosure

Mount the STXplus in an enclosure in an area suitable for the device. The STXplus dimensions are shown on Drawing TI-SP.STXP-01 in Appendix D.

Stand-Alone STXplus with Kistler-Morse® Supplied Enclosure

When mounting the STXplus, be sure there is enough clearance to open the front door completely. The enclosure dimensions are shown on Drawing TI-SP.STXP-01 in Appendix D.

NOTE

Mounting feet are supplied by Kistler-Morse®.

Drilling Holes in the Enclosure

CAUTION

Remove the electronics before drilling enclosure holes. Drill holes through the bottom or side of the enclosure. **DO NOT** drill holes through the top as this may allow moisture seepage, which can damage the electronics and void the warranty.

Follow this procedure to mount the STXplus:

1. Hold the enclosure against the wall in the desired location and mark the positions of the mounting holes. Place the enclosure in a safe place.
2. Drill the mounting holes in the wall.
3. Attach the enclosure to the wall.

The STXplus NEMA-rated enclosure has no openings through which to route cables or install conduit. Before you begin wiring, drill entry holes through the enclosure where it is

most convenient to route the conduit or cables. Hole location is critical for proper PCB installation. Check clearances to ensure fittings and wire routing will not interfere with the PCB or enclosure door. Refer to Drawing TI-SP.STXP-01 in Appendix D.

WIRING SYSTEM

This section describes how to wire the junction box, power, and auxiliary equipment to the STXplus. Refer to the specifications in Appendix A and Drawing TI-SP.STXP-02 in Appendix D.

WARNING!

All wiring must comply with government or local codes.

Wiring Junction Box to STXplus

CAUTION

Do not route junction box cables in the same conduit with AC power cables.

NOTE

1. Seal all conduit fittings against water entry. Install conduit drains at the conduit's lowest elevation(s) to allow condensation to drain.
2. All wiring routed between junction boxes and STXplus must be continuous (no splices).

Wiring Power

WARNING!

When connecting power to this unit, power wiring must comply with the national wiring requirements for the country in which the equipment is installed and the ground conductor must be connected to the protective earth (PE) terminal.

See Appendix D (Page D-8) for Installation Instructions for AC Line Varistors.

Refer to the instructions below and Appendix D.

DC: STXplus operates on 12-30VDC power

AC: STXplus operates on 100-240VAC, 47-63Hz

NOTE

The standard lead colors for AC power in North America are green for ground, black for hot, and white for neutral.

WIRING CURRENT OUTPUT

External Current Loop Power Supply

The STXplus Current Transmitter Loop is powered by the STXplus power supply. However, an external power supply may be desired for some applications. The maximum allowable voltage from the external power supply is 30VDC. The minimum allowable voltage is based on the loop resistance, allowing a 2V overhead for the output's current sensing.

For example:

$$1,000\Omega \times 0.2A = 20V$$

$$\text{Minimum voltage} = 20V + 2V = 22V$$

Wire the current transmitter external power supply as shown in Appendix D. Move the SW9 switch on the STXplus PCB to the Ext position.

Sealing Openings in the Stand-Alone STXplus Enclosure

After conduit and cable installation is complete, seal around the openings in the STXplus enclosure to prevent moisture seepage.

CAUTION

Only use Sikaflex 1A polyurethane sealant or Dow Corning RTV 739 or RTV738. Other sealants may contain acetic acid, which is harmful to electronics.

QUICK REFERENCE

Default

Hold the UP, DOWN, and ENTER buttons while pressing the SW2 reset button.

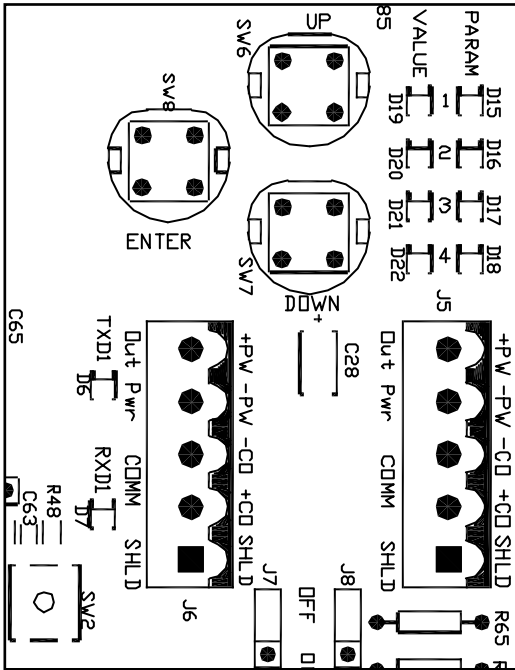

Changing the Modbus or Serial Port Address

Both the Modbus Port and the Serial Port share the same switches to set the port.

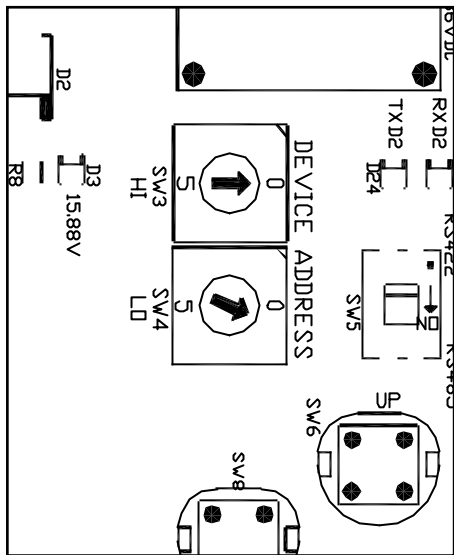

Changing from Half-Bridge 3-Wire to Full-Bridge 4-Wire

Half-bridge will have 12V excitation and full-bridge will have 10V excitation automatically.

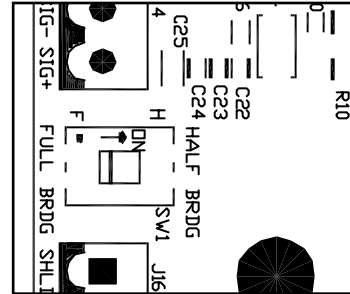

Enabling Remote Sense

The remote sense is used for 6-wire load cells or when barriers are used.

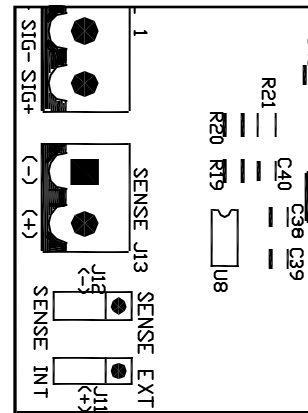

Enabling Remote Loop Voltage for the 0-20mA/4-20mA

This switch is moved to external loop power when a separate power supply will be used to power the current loop.

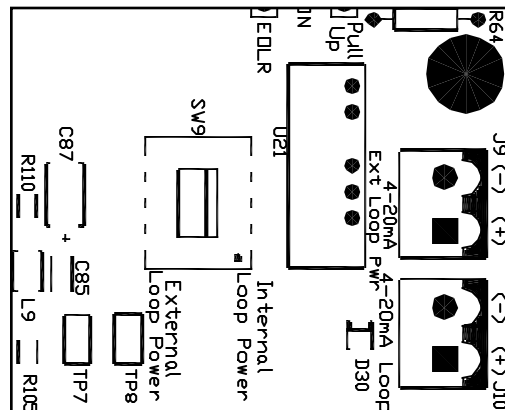

CHAPTER 3: STAND-ALONE ANALOG CALIBRATION AND SET UP

INTRODUCTION

This chapter contains the procedures to perform an analog calibration and set up system parameters for the STXplus.

TRIMMING THE CURRENT OUTPUT

Prior to calibration, check and adjust the current output as necessary. If the calibration of the device receiving the current output does not match the calibration of the current output, follow the appropriate procedure below to trim the 0mA, 4mA, and/or the 20mA current output(s).

If the STXplus is off, apply power and let it warm up for at least 15 minutes before proceeding.

NOTE

If you do not press a button within 15 seconds, the STXplus exits the programming mode.

Trim the 0mA Current Output

1. Press the DOWN or UP buttons until the PARAM LEDs look like:

D15 D16 D17 D18
PARAM ○ ● ● ○

Press the ENTER button.

2. Press the UP button to adjust the 0mA up and press the DOWN button to adjust the 0mA down. When satisfied, press the ENTER button.

Trim the 4mA Current Output

1. Press the DOWN or UP buttons until the PARAM LEDs look like:

D15 D16 D17 D18
PARAM ● ● ● ○

Press the ENTER button.

2. Press the UP button to adjust the 4mA up and press the DOWN button to adjust

the 4mA down. When satisfied, press the ENTER button.

Trim the 20mA Current Output

1. Press the DOWN or UP buttons until the PARAM LEDs look like:

D15 D16 D17 D18
PARAM ○ ○ ○ ●

Press the ENTER button.

2. Press the UP button to adjust the 20mA up and press the DOWN button to adjust the 20mA down. When satisfied, press the ENTER button.

Figure 3-1. Two Methods for Connecting an Ammeter.

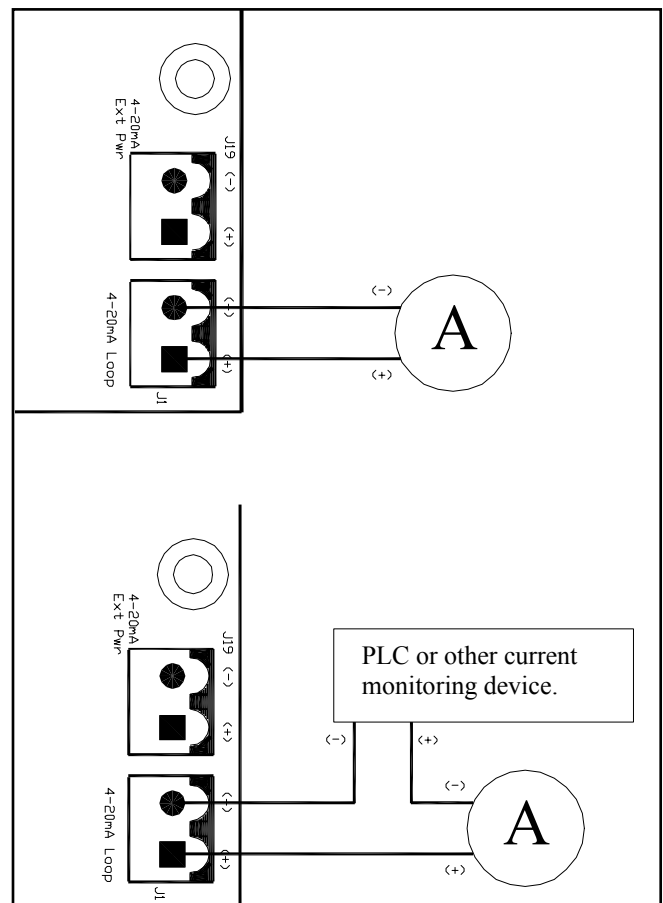

SETTING UP CURRENT OUTPUT OPERATING MODE (0-20mA, 4-20mA, 20-4mA, and 20-0mA)

This procedure sets up the current output engine such that zero to maximum input range results in either a 0-20mA, 4-20mA, 20-4mA, or 20-0mA output range.

Setting Mode

1. Press the DOWN or UP buttons until the PARAM LEDs look like:

D15 D16 D17 D18
PARAM ● ○ ○ ○

Press the ENTER button.

2. Press the UP or DOWN buttons until the appropriate current mode/range is achieved as indicated by the VALUE LEDs as shown below:

0-20mA D19 D20 D21 D22
VALUE ○ ● ○ ○

4-20mA D19 D20 D21 D22
VALUE ● ○ ○ ○

20-4mA D19 D20 D21 D22
VALUE ● ● ○ ○

20-0mA D19 D20 D21 D22
VALUE ○ ○ ● ○

Press the ENTER button.

SETTING UP THE INPUT VOLTAGE RANGE

This procedure sets up the input voltage range for all 4 channels simultaneously.

Setting Range

1. Press the DOWN or UP buttons until the PARAM LEDs look like:

D15 D16 D17 D18
PARAM ● ○ ● ●

Press the ENTER button.

2. Press the UP or DOWN buttons until the appropriate input voltage range is achieved as indicated by the VALUE LEDs as shown below:

±2V D19 D20 D21 D22
VALUE ● ○ ○ ○

±1V D19 D20 D21 D22
VALUE ○ ● ○ ○

±500mV D19 D20 D21 D22
VALUE ● ● ○ ○

±75mV D19 D20 D21 D22
VALUE ○ ○ ● ○

Press the ENTER button.

SETTING UP CHANNEL ENABLE

This procedure enables the desired channel inputs.

1. Press the DOWN or UP buttons until the PARAM LEDs look like:

D15 D16 D17 D18
PARAM ● ● ● ●

Press the ENTER button.

2. Press the UP or DOWN buttons until the appropriate channels as represented by the VALUE LEDs are illuminated where D19 corresponds to Channel 4, D18 corresponds to Channel 3, etc. Press the ENTER button when the desired input channel(s) is configured. **The default is for Channel 1 only (D22).**

NOTE

The STXplus must be in gross mode prior to calibration.

ANALOG CALIBRATION

Analog calibration calibrates the STXplus “analog engine.”

There are three methods for performing an analog calibration:

1. High-accuracy calibration.
2. Calibration by adding a known quantity of material.
3. Calibration by subtracting a known quantity of material.

Each method requires moving a known quantity of material into or out of the vessel. The high-accuracy calibration requires the vessel be completely empty or completely full to start. The latter two methods do not provide the highest possible accuracy. However, they do provide accurate calibration. If you need the greatest accuracy, perform a high-accuracy calibration.

Before starting calibration, connect an ammeter to the STXplus. See Figure 3-1 on Page 3-1.

If a current monitoring device is connected to the 4-20mA loop, connect an ammeter in series with the device.

Figure 3-2. High-Accuracy Calibration.

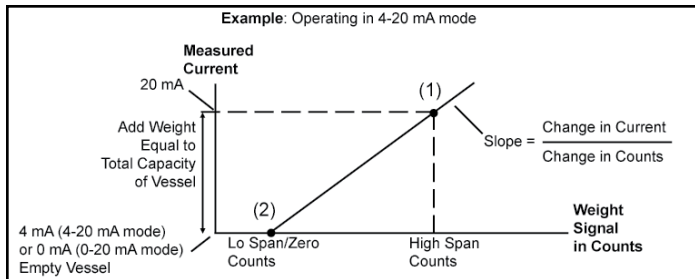

If a monitoring device is not being used, connect the ammeter positive (+) lead to the positive (+) terminal of the current loop. Connect the negative (-) lead to the negative (-) terminal of the current loop.

If the STXplus is off, apply power and let it warm up for at least 15 minutes before proceeding.

High-Accuracy Calibration

This procedure provides the highest accuracy, but requires the vessel be completely empty or completely full. The principle behind the calibration is shown in Figure 3-2 for starting with an empty vessel.

Starting with an Empty Vessel

1. Empty the vessel completely.
2. Press the DOWN or UP buttons until the PARAM LEDs look like:
 D15 D16 D17 D18
 PARAM ○ ○ ● ○
 Press the ENTER button.
3. Press the UP or DOWN buttons until the appropriate current output is achieved (0mA if in 0-20mA mode, 4mA if in 4-20mA mode, or 20mA if in either 20-4mA mode or 20-0mA mode). Press the ENTER button.

4. Fill the vessel.
5. Press the DOWN or UP buttons until the PARAM LEDs look like:

D15 D16 D17 D18
 PARAM ● ○ ● ○

6. Press the UP or DOWN buttons until the appropriate current output is achieved (20mA if in 4-20mA or 0-20mA mode, 4mA if in 20-4mA mode or 0mA if in 20-0mA mode). Press the ENTER button.

NOTE

If you do not press a button within 15 seconds the STXplus exits the programming mode. Once step 3 has been completed above, the LO Span value will be restored.

Starting with a Full Vessel

1. Empty the vessel completely.
2. Press the DOWN or UP buttons until the PARAM LEDs look like:



Press the ENTER button.

3. Press the UP or DOWN buttons until the appropriate current output is achieved (20mA if in 4-20mA or 0-20mA mode, 4mA if in 20-4mA mode or 0mA if in 20-0mA mode). Press the ENTER button.
4. Empty the vessel.
5. Press the DOWN or UP buttons until the PARAM LEDs look like:



Press the ENTER button.

6. Press the UP or DOWN buttons until the appropriate current output is achieved (0mA if in 0-20mA mode, 4mA if in 4-20mA mode, or 20mA if in either 20-4mA mode or 20-0mA mode). Press the ENTER button.

NOTE

If you do not press a button within 15 seconds the STXplus exits the programming mode. Once step 3 has been completed above, the HI Span value will be restored.

Calibration by Adding or Subtracting a Known Quantity of Material

This calibration method does not require the vessel to be completely empty.

LO Span (See (1) in Figure 3-3) is set to the expected current output. A known quantity of material, representing at least 25% of the vessel's total capacity, is added to the vessel. HI Span (See (2) in Figure 3-3) is set to the expected current output. Points (1) and (2) define the straight line. The slope of the line is call the Scale Factor, which is calculated internally. Zero (See (3) in Figure 3-3) is calculated.

The calibration is reasonably accurate because it is based on the known difference between the currents (based on the difference in weights) and counts. However, if the estimated weight is incorrect, the actual location of the line is incorrect, resulting in errors in output. The greater the error in the estimated weight, the greater the resulting error.

Figure 3-3. Calibration by Adding a Known Quantity of Material.

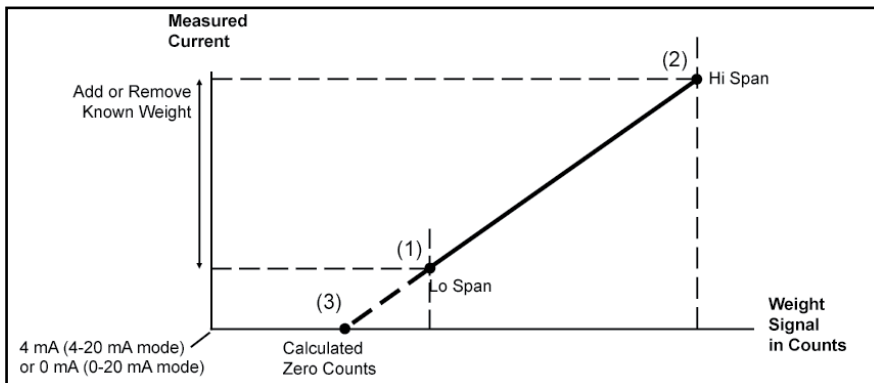

The accuracy of the calibration will improve with a greater quantity of material added during the calibration procedure. For example, adding 50% of the vessel's total capacity results in greater accuracy than adding 25% of the total capacity.

Example: Operating in 4-20mA mode, maximum vessel live load = 100,000lb (100%), current live load = 25,000lb (25%).

1. Input LO span point as 8mA corresponding to 25% from Table 3-1.
2. Add 50,000lb to vessel to make current live load = 75,000lb (75%).
3. Input HI span point as 16mA corresponding to 75% from Table 3-1.

Table 3-1. Proportional Current Outputs.

0-20 mA Mode		4-20 mA Mode	
Current Output (mA)	% of Maximum Live Load	Current Output (mA)	% of Maximum Live Load
0	0	4	0
1	5	5	6.25
2	10	6	12.5
3	15	7	18.75
4	20	8	25
5	25	9	31.25
6	30	10	37.5
7	35	11	43.75
8	40	12	50
9	45	13	56.25
10	50	14	62.5
11	55	15	68.75
12	60	16	75
13	65	17	81.25
14	70	18	87.5
15	75	19	93.75
16	80	20	100
17	85		
18	90		
19	95		
20	100		

Calibration by Adding a Known Quantity of Material

1. Press the DOWN or UP buttons until the PARAM LEDs look like:

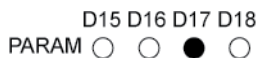

Press the ENTER button.

2. Press the UP or DOWN buttons until the appropriate current output is achieved. Press the ENTER button.
3. Add a known quantity of material to the vessel.
4. Press the DOWN or UP buttons until the PARAM LEDs look like:



Press the ENTER button.

5. Press the UP or DOWN buttons until the appropriate current output is achieved. Press the ENTER button.

NOTE

If you do not press a button within 15 seconds the STXplus exits the programming mode. Once step 2 has been completed above, the LO Span value will be restored.

Calibration by Subtracting a Known Quantity of Material

1. Press the DOWN or UP buttons until the PARAM LEDs look like:



Press the ENTER button.

3. Press the UP or DOWN buttons until the appropriate current output is achieved. Press the ENTER button.
4. Remove a known quantity of material from the vessel.
5. Press the DOWN or UP buttons until the PARAM LEDs look like:

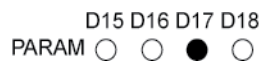

Press the ENTER button.

6. Press the UP or DOWN buttons until the appropriate current output is achieved. Press the ENTER button.

NOTE

If you do not press a button within 15 seconds the STXplus exits the programming mode. Once step 2 has been completed above, the HI Span value will be restored.

SYSTEM SET UP

The STXplus allows you to set up system parameters using the programming buttons (See Table 3-2 on Page 3-9). This provides the ability to set up the system without the use of an external device. The programming buttons are used to set up the following parameters:

1. Current Output Range
2. Current Output Tracking
3. Current Output Fail-safe
4. LO Span and HI Span
5. 0mA, 4mA, and 20mA Trim
6. Serial Port 1 Baud Rate/Protocol
7. Averaging Factor
8. DSP Filter
9. DSP Enable
10. DSP Step
11. Input Voltage Range
12. Modbus Baud Rate
13. Channel Enable

DESCRIPTIONS**Current Output Range**

The analog current transmitter may be set to transmit current output based on either 0-20mA, 4-20mA, 20-4mA, or 20-0mA. **The default is 4-20mA.**

Current Output Tracking

The analog current transmitter may be set to transmit based on either net weight or gross weight. If a tare is going to be performed, this must be set to net. **The default is gross weight.**

Current Output Fail-safe

If the STXplus detects a problem, one of three fail-safe (Fsafe) conditions can be applied to the analog current output:

1. 0mA or 4mA
2. 20mA
3. No change.

The default is no change.

Following are examples of fail-safe conditions:

1. Analog-to-digital converter over range/under range condition.
2. Engineering units over range.
3. Communication error with the STXplus PCB.

LO Span and HI Span

The LO Span and HI Span set the calibration points based on material weight in the tank. When a LO Span or HI Span is entered, the STXplus reads the input signal from the sensors and stores this data. See Figure 3-3.

0mA, 4mA, and 20mA Trim

If the current output of the STXplus does not match the device receiving the output, it can be trimmed. This function should be completed before calibration.

Serial Port 1 Baud Rate/Protocol

The serial port baud rate determines the speed with which the STX communicates and the protocol to an ORB 2.2, a remote monitor, or remote display. **The default is 9600 with Kistler-Morse® protocol.**

Averaging Factor

This parameter sets the number of readings (from 1 to 100) the STXplus averages for each output. The STXplus calculates a running average. The larger the number of readings in the running average, the smaller effect a variation in signal has on

the average. This results in fewer variations in output. For example, fewer variations in a display reading results in a display that is easier to read. The averaging factor affects the value seen on a display as well as current outputs and serial outputs. **The default is 5.** No more than 20 is advised.

DSP Filter

Vibrations in a vessel can cause changes in the STXplus output, even though no material is moved, because the vibrations affect the vessel's structural response. The Sentry™ DSP Filter reduces output changes that can result from vibration.

The A/D converter digitizes the signal coming from a sensor. The STXplus picks the first signal as a reference median; this value is used in calculating the output. As shown in Figure 3-4, the STXplus then compares the following signals to the reference median when either of the following happen:

1. The number of successive signals above or below the median exceeds a triggering number.
2. A signal falls outside a user-defined window around the reference median.

When the STXplus recalculates the reference median, the transmitted data changes to correspond to the new reference median. The DSP Filter affects the STXplus current output as well as the serial output.

The DSP, when in analog mode, will use a default factor of 80% and a quality of 3.

DSP Enable

DSP Enable turns the DSP Filter on and off. **The default state is on.**

DSP Step

DSP Step is a window, in percent, of span above and below the reference median.

As shown in on the left side of Figure 3-4, if a large signal change is detected that falls outside of the window, the STXplus immediately moves the location of the reference median to that point. This allows the STXplus to adjust quickly to rapid material movement. **The default step is 0.5% of span.**

Input Voltage Range

The type of sensors connected to the STXplus determines the required setting.

An input range of $\pm 75\text{mV}$ is used with full-bridge sensors of 2mV/V or 3mV/V .

An input range of $\pm 0.5\text{V}$ is used with half-bridge load cells. Some high output half-bridge applications may require $\pm 1\text{V}$ or $\pm 2\text{V}$.

The default range is $\pm 0.5\text{V}$ for Kistler-Morse® Microcell and Load Cell sensors.

An input range of $\pm 0.5\text{V}$ is appropriate for Kistler-Morse® Load Disc II, LD360s, LD3, and Load Stand II sensors. An input range of $\pm 75\text{mV}$ is appropriate for Kistler-Morse® LD3xi, LD3xiC, TC-1, or other full-bridge sensors.

Amplifier Gain	Sensor Input Range
1	$\pm 2\text{V}$
2	$\pm 1\text{V}$
4	$\pm 0.5\text{V}$
32	$\pm 75\text{mV}$

Modbus Baud Rate

The setting determines the baud rate for RS-485 port serial communication. **The default is 115K baud rate.**

Channel Enable

Enables/disables Channels 1-4. **The default is Channel 1 only.**

Figure 3-4. DSP Filter Examples.

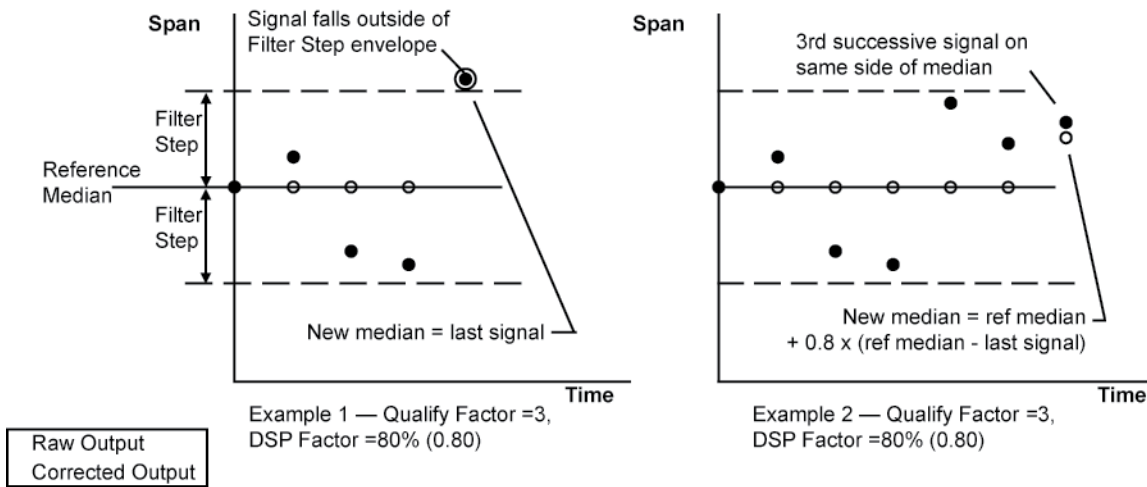

TARE

The tare feature allows you to tare or “zero” a vessel. Tare is useful when you want to monitor how much material is added to or removed from the vessel from a given point. The effect is as follows:

1. If the STXplus current output is in net mode, the current output will correspond to the change in weight since the last time the vessel was tared, rather than the total weight of material in the vessel.
2. If the STXplus is being serially communicated to via an ORB 2.2 or other device, then a tare command will perform a tare. If setpoints are set up based on net weight, their activation will correspond to the net weight.
3. If the STXplus is stand-alone, press the ENTER button when no PARAM LEDs are lit.
4. A calibration should only be done while in gross mode.

APPENDIX A: PRODUCT SPECIFICATIONS

ANALOG INPUT

Resolution. Selectable 16 bit (1 part in 65,536) to 23 bit (1 part in 8,388,607) in 1-bit increments.

Conversion Speed. 16msec at 16 bit-19 bit, 30msec at 20 bit, 59msec at 21 bit, 120msec at 22 bit, and 240msec at 23 bit.

Span. Programmable between $\pm 2V$ and $\pm 15.6mV$.

Temperature Stability. Zero 10ppm/ $^{\circ}C$; Span 80ppm/ $^{\circ}C$.

Common Mode Rejection. 100db minimum.

Normal Mode Rejection. 86db minimum at 60Hz.

Programmable Filter. Sentry™ DSP Filter.

SERIAL COMMUNICATIONS PORTS

Port 1. RS-422/RS-485 switchable; Baud Rate - 9600, 19.2K, 38.4K, 115.2K; For multi-drop single cable connect to optional remote marque display or slave communications via Kistler-Morse® protocol.

Port 2. RS-485; Baud Rate - 9600, 19.2K, 38.4K, 115.2K; Modbus RTU protocol.

ANALOG OUTPUT

Format. 0-20mA, 4-20mA, 20-0mA, or 20-4mA.

Resolution. 16 bit (1 part in 65,536).

Isolation. 500VAC.

Maximum Load. 600 Ω with internal loop supply; up to 2400 Ω with external loop supply.

DIGITAL OUTPUT

2 Mechanical Relays. 2.5A AC output.

EXCITATION OUTPUT

12VDC in half-bridge mode/10VDC in full-bridge mode; both with remote sense capabilities.

POWER REQUIREMENTS (sensors not included)

DC Power (standard). 14.4VDC to 30.0VDC at 300mA.

AC Power (optional). 100-240VAC, 20 watts maximum, 47-63Hz.

ENVIRONMENTAL

Operating Temperature. 14 $^{\circ}F$ to 122 $^{\circ}F$ (-10 $^{\circ}C$ to 50 $^{\circ}C$).

Storage Temperature. -40 $^{\circ}F$ to 158 $^{\circ}F$ (-40 $^{\circ}C$ to 70 $^{\circ}C$).

Humidity. 1% to 95% (non-condensing).

OPTIONAL ENCLOSURES

Fiberglass. NEMA 4X, IP66.

Stainless Steel. NEMA 4X, IP66.

APPENDIX B: KISTLER-MORSE® PROTOCOL SERIAL COMMANDS

INTRODUCTION

This appendix contains the serial commands and Kistler-Morse® protocol syntax used for serial communications between the host or master (PC, etc.) and the STXplus. Detailed explanations and examples of the commands are included. If any parameter or set of parameters that are transmitted by the master are outside of the acceptable range an 'N' will be transmitted back by the STXplus.

COMMAND TABLE

Table B-1. Kistler-Morse® Protocol Serial Commands.

Command		Function	Transmitted by Master ¹	Transmitted by STXplus ¹
Hex	ASCII			
23	#	Product ID	>aa#ssr	A3669r
75,31	u1	A/D counts unfiltered	>aa1ssr	A(-)dddddddssr
75,32	u2	A/D counts filtered	>aa2ssr	A(-)dddddddssr
57	W	Gross weight	>aaWssr	A(-)ffffffssr
42	B	Net weight	>aaBssr	A(-)ffffffssr
54	T	Perform Tare	>aaTssr	Ar
47,31	G1	Read units	>aaG1ssr	A???ssr
50,31	P1	Write units	>aaP1???ssr	Ar
52,61	Ra	Read format	>aaRassr	A000000dssr
77,61	wa	Write format	>aawa000000dssr	Ar
41	A	Read current output as a percent	>aaAssr	Affffffssr
6F	o	Default calibration constants only	>aaosssr	Ar
69	i	Default entire STXplus EEPROM	>aaissr	Ar
48	H	Perform Auto Hi-Span	>aaH(-)ffffffssr	Adssr ²
4C	L	Perform Auto Lo-Span	>aaL(-)ffffffssr	Adssr ²
5A	Z	Perform Auto Zero	>aaZ(-)ffffffssr	Adssr ²
56,30	V0	Version	>aaV0ssr	AHHssr
47,30	G0	Read vessel name	>aaG0ssr	A?????????ssr
50,30	P0	Write vessel name	>aaP0?????????ssr	Ar
6E,31	n1	Read analog/digital mode flag	>aan1ssr	A000000dssr
6D,31	m1	Write analog/digital mode flag	>aam1000000dssr	Ar
6E,32	n2	Read current range mode	>aan2ssr	A000000dssr
6D,32	m2	Write current range mode	>aam2000000dssr	Ar
52,31	R1	Read digital delta counts	>aaR1ssr	A(-)dddddddssr
77,31	w1	Write digital delta counts	>aaw1(-)dddddddssr	Ar
52,32	R2	Read digital delta weight	>aaR2ssr	A(-)ffffffssr
77,32	w2	Write digital delta weight	>aaw2(-)ffffffssr	Ar
52,33	R3	Read digital zero counts	>aaR3ssr	A(-)dddddddssr
77,33	w3	Write digital zero counts	>aaw3(-)dddddddssr	Ar
52,34	R4	Read digital zero weight	>aaR4ssr	A(-)ffffffssr
77,34	w4	Write digital zero weight	>aaw4(-)ffffffssr	Ar
52,35	R5	Read digital Hi-Span counts	>aaR5ssr	A(-)dddddddssr
77,35	w5	Write digital Hi-Span counts	>aaw5(-)dddddddssr	Ar

APPENDIX B: KISTLER-MORSE® PROTOCOL SERIAL COMMANDS

77,33	w3	Write digital zero counts	>aaw3(-)dddddddssr	Ar
52,34	R4	Read digital zero weight	>aaR4ssr	A(-)ffffffssr
77,34	w4	Write digital zero weight	>aaw4(-)ffffffssr	Ar
52,35	R5	Read digital Hi-Span counts	>aaR5ssr	A(-)dddddddssr
77,35	w5	Write digital Hi-Span counts	>aaw5(-)dddddddssr	Ar
52,36	R6	Read digital Hi-Span weight	>aaR6ssr	A(-)ffffffssr
77,36	w6	Write digital Hi-Span weight	>aaw6(-)ffffffssr	Ar
52,37	R7	Read digital Lo-Span counts	>aaR7ssr	A(-)dddddddssr
77,37	w7	Write digital Lo-Span counts	>aaw7(-)dddddddssr	Ar
52,38	R8	Read digital Lo-Span weight	>aaR8ssr	A(-)ffffffssr
77,38	w8	Write digital Lo-Span weight	>aaw8(-)ffffffssr	Ar
52,42	RB	Read analog delta counts	>aaR9ssr	A(-)ffffffssr
77,42	wB	Write analog delta counts	>aaw9(-)ffffffssr	Ar
52,43	RC	Read analog zero counts	>aaRCssr	A(-)ffffffssr
77,43	wC	Write analog zero counts	>aawC(-)ffffffssr	Ar
52,44	RD	Read Tare weight	>aaRDssr	A(-)ffffffssr
77,44	wD	Write Tare weight	>aawD(-)ffffffssr	Ar
61,52	aR	Read averaging value	>aaaRssr	A0000dddssr
61,57	aW	Write averaging value	>aaaW0000dddssr	Ar
6E,35	n5	Read DSP filter enable	>aan5ssr	A000000dssr
6D,35	m5	Write DSP filter enable	>aam5000000dssr	Ar
52,58	RX	Read DSP filter factor	>aaRXssr	A0000dddssr
77,58	wX	Write DSP filter factor	>aawX0000dddssr	Ar
52,59	RY	Read DSP filter step	>aaRYssr	Affffffssr
77,59	wY	Write DSP filter step	>aawYffffffssr	Ar
52,5A	RZ	Read DSP filter qualify	>aaRZssr	A000000dssr
77,5A	wZ	Write DSP filter qualify	>aawZ00000dddssr	Ar
5B,52,31	[R1	Read 20mA trim value	>aa[R1ssr	A00dddssr
5B,57,31	[W1	Write 20mA trim value	>aa[W100dddssr	Ar
5B,52,32	[R2	Read 4mA trim value	>aa[R2ssr	A00dddssr
5B,57,32	[W2	Write 4mA trim value	>aa[W200dddssr	Ar
5B,52,33	[R3	Read 0mA trim value	>aa[R3ssr	A00dddssr
5B,57,33	[W3	Write 0mA trim value	>aa[W300dddssr	Ar
52,39	R9	Read current output high weight	>aaR9ssr	A(-)ffffffssr
77,39	w9	Write current output high weight	>aaw9(-)ffffffssr	Ar
52,41	RA	Read current output low weight	>aaRAssr	A(-)ffffffssr
77,41	wA	Write current output low weight	>aawA(-)ffffffssr	Ar
74,48	tH	Read current output failsafe mode	>aatHssr	A000000dssr
62,48	bH	Write current output failsafe mode	>aabH000000dssr	Ar
74,49	tI	Read current output test mode	>aatIssr	A000000dssr
62,49	bI	Write current output test mode	>aabI000000dssr	Ar
74,47	tG	Read current output tracking mode	>aatGssr	A000000dssr
62,47	bG	Write current output tracking mode	>aabG000000dssr	Ar
74,4A	tJ	Read current output value in counts	>aatJssr	A00dddssr
62,4A	bJ	Write current output value in counts	>aabJ00dddssr	Ar
47,49	GI	Read Setpoint Deadband value	>aaGIssr	A(-)ffffffssr
50,49	PI	Write Setpoint Deadband value	>aaPI(-)ffffffssr	Ar
47,38	G8	Read Setpoint failsafe mode	>aaG8ssr	A000000dssr

APPENDIX B: KISTLER-MORSE® PROTOCOL SERIAL COMMANDS

50,38	P8	Write Setpoint failsafe mode	>aaP8n000000dssr	Ar
47,39	G9	Read Setpoint High/Low mode	>aaG9nssr	A000000dssr
50,39	P9	Write Setpoint High/Low mode	>aaP9n000000dssr	Ar
47,37	G7	Read Setpoint tracking mode	>aaG7nssr	A000000dssr
50,37	P7	Write Setpoint tracking mode	>aaP7n000000dssr	Ar
47,54	Rg	Read Setpoint state	>aaRgnssr	A000000dssr
50,54	wg	Write Setpoint state	>aawgn000000dssr	Ar
47,42	GB	Read Setpoint test mode	>aaGBnssr	A000000dssr
50,42	PB	Write Setpoint test mode	>aaPBn000000dssr	Ar
47,48	GH	Read Setpoint value	>aaGHnssr	A(-)ffffffssr
50,48	PH	Write Setpoint value	>aaPHn(-)ffffffssr	Ar
	GS	Read Raw linearization data	>aaGSnssr	A(-)ffffffssr
	PS	Write Raw linearization Pt. data	>aaPSn(-)ffffffssr	Ar
	GT	Read corrected linearization Pt. 2 data	>aaGTnssr	A(-)ffffffssr
	PT	Write corrected linearization Pt. 2 data	>aaPTn(-)ffffffssr	Ar
	n3	Read linearization mode	>aan3ssr	A000000dssr
	m3	Write linearization mode	>aam3000000dssr	Ar
	K1	Read AB-RIO PCB present	>aaK1ssr	A000000dssr
	K2	Read AB-RIO baudrate setup	>aaK2ssr	A000000dssr
	L2	Write AB-RIO baudrate setup	>aal.2000000dssr	Adssr
	K3	Read AB-RIO address	>aaK3ssr	A0000dddssr
	L3	Write AB-RIO address	>aal.30000dddssr	Adssr
	K4	Read AB-RIO group setup	>aaK4ssr	A000000dssr
	L4	Write AB-RIO group setup	>aal.4000000dssr	Adssr
	K5	Read AB-RIO rack size setup	>aaK5ssr	A000000dssr
	L5	Write AB-RIO rack size setup	>aal.5000000dssr	Adssr
	K6	Read AB-RIO last rack setup	>aaK6ssr	A000000dssr
	L6	Write AB-RIO last rack setup	>aal.6000000dssr	Adssr
	K7	Read AB-RIO mode setup	>aaK7ssr	A000000dssr
	L7	Write AB-RIO mode setup	>aal.7000000dssr	Adssr
	K8	Read DeviceNet PCB present	>aaK8ssr	Adddddddssr
	K9	Read DeviceNet address	>aaK9ssr	A000000dssr
	L9	Write DeviceNet address	>aal.9000000dssr	Adssr
	KA	Read DeviceNet baudrate setup	>aaKAssr	A000000dssr
	LA	Write DeviceNet baudrate setup	>aal.A000000dssr	Adssr
	KB	Read DeviceNet serial number	>aaKBssr	A????ssr
	KC	Read ProfiBus PCB present	>aaKCssr	A000000dssr
	KD	Read ProfiBus address	>aaKDssr	A0000dddssr
	LD	Write ProfiBus address	>aal.D0000dddssr	Adssr
	RW	Read DSP Step monitor value	>aaRWssr	>Affffffssr
	wW	Write DSP Step monitor on/off	>aawWddddddssr	Ar
	e1	Read Serial Port 1 baudrate	>aae1ssr	>A000000dssr
	g1	Write Serial Port 1 baudrate	>aag1000000dssr	Ar
	g2	Write Serial Port 1 protocol	>aag2000000dssr	Ar
	e3	Read Modbus baudrate	>aae3ssr	A000000dssr
	g3	Write Modbus baudrate	>aag3000000dssr	Ar

Notes:

¹ See Table B-2 for definitions of the characters in the command strings.

² d is the return status code:

Table B-2. Definitions of Characters in Command Strings.

>	Start of message character.
aa	Two digit ASCII Hex character address of the STXplus.
d	One digit ASCII decimal number data.
dd	Two digit ASCII decimal number data.
dd...	More than two digits of ASCII decimal number data.
hh	Two digit ASCII Hex number, upper nibble, lower nibble.
ss	Two digit ASCII Hex checksum of characters added between '>' or 'A' and checksum characters. See Checksum Calculation in this appendix for an explanation of how checksum is calculated. Note that the '?' character in place of the checksum characters is a wildcard and therefore ignores the checksum.
r	Carriage return (0x0D)
A	Acknowledge character (0x41)
N	Not acknowledge character (0x4E)
(-)	Normally indicates polarity. In some cases if an error is present, an 'X' displays with an error code (ASCII digits) immediately following. Possible error codes and definitions are: <ul style="list-style-type: none"> • 6 -- ADC over range error • 7 -- Gross or Net weight engineering units overflow
??...	Two or more ASCII characters
n	Indicates the setpoint number or linearization table point number
ff...	Two or more digit ASCII number data with an embedded decimal point.

CHECKSUM CALCULATION

The 1-byte checksum is calculated by adding the hex values of all ASCII characters between the start of message character '>' or acknowledge character 'A' and the checksum character 'ss.' Overflows from the addition are ignored.

Request

To request gross engineering units (such as weight) from an STXplus, the command is:
>aaWssr

If the STXplus's address is '3', the command is:
>03Wssr

Calculating the checksum 'ss' as the sum of the Hex values of all characters between '>' and 'ss':
03W ASCII = 30 Hex + 33 Hex + 57 hex = BA Hex
 '0' '3' 'W'

Therefore, the ASCII string transmitted to the STXplus is:

```
> 0 3 W B A CR
3E 30 33 57 42 41 0D Hex
```

Response

The response to a request for gross engineering units is:

A(-)ddddddssr

If the weight is +6384, the response is:

A+0006384ssr

Calculating the checksum 'ss' as the sum of the Hex values of all characters between 'A' and 'ss':

+0006384 ASCII = 2B Hex+30 Hex+30 Hex+30 Hex+36 Hex+33 Hex+38 Hex+34 Hex = 190 Hex
 '+' '0' '0' '0' '6' '3' '8' '4'

Ignoring the overflow, the checksum is 90 Hex. Therefore, the ASCII string transmitted back to the master is:

A + 0 0 0 6 3 8 4 9 0 CR
 41 2B 30 30 30 36 33 38 34 39 30 0D Hex

EXAMPLES

For each command below, the general format of the command is shown above the example.

'#' Command – Kistler-Morse® Product Identification Number

This command is sent by the master to request the STXplus to send its Kistler-Morse® product identification code (code is 36 for the STXplus). For this example, the master requests the code from an STXplus at address 01, which returns a code of 36 and a checksum of 69.

Request from Master	Response from STXplus
>aa#ssr	Addssr Format
>01#84r	A3669r Example

'u1' Command – Request Raw Counts

This command is sent by the master to request the STXplus to send the raw A/D counts. The range of this value can be ±8,388,607. For this example, the master requests the raw counts from an STXplus at address 01, which returns a raw count of 1147226 and a checksum of 67.

Request from Master	Response from STXplus
>aau1ssr	A(-)ddddddssr Format
>01u107r	A114722667r Example

'u2' Command – Request Filtered Counts

This command is sent by the master to request the STXplus to send the filtered A/D counts. The range of this value can be ±8,388,607. For this example, the master requests the raw counts from an STXplus at address 01, which returns a raw count of -17226 and a checksum of 2F.

Request from Master	Response from STXplus
>aau1ssr	A(-)ddddddssr Format
>01u208r	A-172262Fr Example

‘W’ Command – Engineering Units (gross)

This command is sent by the master to request the STXplus to send the gross engineering units (weight, level, etc.). The range of this value can be $\pm 2,147,483,647$. For this example, the master requests the gross weight from an STXplus at address 01, which returns a gross weight of +7103.6 and a checksum of 2F assuming that the format selected was 3(X.X).

Request from Master	Response from STXplus
>aaWssr	A(-)ffffffssr Format
>01WB8r	A7103.62Fr Example

‘B’ Command – Engineering Units (net)

This command is sent by the master to request the STXplus to send the net engineering units (weight, level, etc). The range of this value can be $\pm 2,147,483,647$. For this example, the master requests the net weight from an STXplus at address 01, which returns a net weight of -4466. and a checksum of 2F assuming tht the format selected was 2(X.).

Request from Master	Response from STXplus
>aaBssr	A(-)ffffffssr Format
>01BA3r	A-4466.2Fr Example

‘T’ Command – Perform Tare

This command is sent by the master to request the STXplus to tare itself. For this example, the master requests the tare for an STXplus at address 01.

Request from Master	Response from STXplus
>aaTssr	Ar Format
>01TB5r	Ar Example

‘G1’ Command – Read Configured Units

This command is sent by the master to request the STXplus to send the configured 3 character units designator. The default value is “ “. For this example, the master requests the units for an STXplus at address 01 which returns the units configured of “lbs” and a checksum of 41.

Request from Master	Response from STXplus
>aaG1ssr	A???ssr Format
>01G1D9r	Albs41r Example

‘P1’ Command – Write Configured Units

This command is sent by the master to set the STXplus configured 3 character units designator. For this example, the master sends a unit designator of “kgs” to an STXplus at address 01.

Request from Master	Response from STXplus
>aaP1???ssr	Ar Format
>01P1kgsC6r	Ar Example

‘Ra’ Command – Read Format

This command is sent by the master to request the STXplus to send the configured decimal format. The range of returned values is 0-7 corresponding to X00., X0., X., X.X, X.XX, X.XXX, X.XXXX, X.XXXXX respectively. The default value is 2(X.). For this example, the master requests the format for an STXplus at address 01 which returns the format of 2(X.) and a checksum of 52.

Request from Master	Response from STXplus
>aaRassr	A000000dssr Format
>01Ra14r	A000000252r Example

‘wa’ Command – Write Format

This command is sent by the master to set the STXplus decimal format. The range of acceptable values is 0-7 corresponding to X00., X0., X., X.X, X.XX, X.XXX, X.XXXX, X.XXXXX respectively. For this example, the master will set the decimal format to 4 to an STXplus at address 01. Any of the 6 leading zeros may be omitted.

Request from Master	Response from STXplus
>aawa000000dssr	Ar Format
>01wa00000048Dr	Ar Example

‘A’ Command – Read Current Output

This command is sent by the master to request the STXplus to send the current output as a percentage of maximum current range with an accuracy in tenths of a percent. The range of returned values is 0.0 to 100.0. For this example, the master requests the current output for an STXplus at address 01 which returns value of 37.2(%) and a checksum of 5A.

Request from Master	Response from STXplus
>aaAssr	A000000dssr Format
>01AA2r	A00037.25Ar Example

If an error condition exists an additional ‘X’ and a status digit precedes the current output. Possible status digits are ‘6’ - A/D error, and ‘3’ - current output error. For this example, the master requests the current output for an STXplus at address 01 which has an A/D error and a current output of 89.0(%) and a checksum of 8D.

Request from Master	Response from STXplus
>aaAssr	A000000dssr Format
>01AA2r	AX6089.08Dr Example

'o' Command – Default Calibration Constants Only

This command is sent by the master to request the STXplus to default only the calibration constants. For this example, the master requests the STXplus at address 01 to default its calibration constants.

Request from Master	Response from STXplus
>aaossr	Ar Format
>01oD0r	Ar Example

'i' Command – Default STXplus

This command is sent by the master to request the STXplus to reset to default conditions. For this example, the master requests the STXplus at address 01 to default itself.

Request from Master	Response from STXplus
>aaissr	Ar Format
>01iCAr	Ar Example

'H' Command – Perform HI Span Calibration

This command is sent by the master to request the STXplus calibrate its current input A/D to correspond with the engineering units value that was sent by the master by adjusting it's HI Span calibration points. The range of this value can be $\pm 2,147,483,647$. The response from the STXplus will be a single digit status where 0 for successful, 1 for successful but there was a less than desirable difference between the HI Span and LO Span values, or 2 for successful but the HI Span value was less than the LO Span value. For this example, the master sends the STXplus at address 01 a value of 14356.2 assuming that the format is set to 3(X.X).

Request from Master	Response from STXplus
>aaH±ffffffssr	Ar Format
>01H14356.20Cr	A030r Example

'L' Command – Perform LO Span Calibration

This command is sent by the master to request the STXplus calibrate its current input A/D to correspond with the engineering units value that was sent by the master by adjusting it's LO Span calibration points. The range of this value can be $\pm 2,147,483,647$. The response from the STXplus will be a single digit status where 0 for successful, 1 for successful but there was a less than desirable difference between the HI Span and LO Span values, or 2 for successful but the HI Span value was less than the LO Span value. For this example, the master sends the STXplus at address 01 a value of -96700. assuming that the format is set to 0(X00.) and the difference between the HI Span and the LO Span values was less than desirable.

Request from Master	Response from STXplus
>aaL±ffffffssr	Ar Format
>01L-96700.0Er	A131r Example

‘Z’ Command – Perform Zero Calibration

This command is sent by the master to request the STXplus calibrate its current input A/D to correspond with the engineering units value that was sent by the master by adjusting the zero weight crossing point rather than adjusting the slope of delta counts/delta weight. The range of this value can be ±2,147,483,647. The response from the STXplus will be a single digit status where 0 - successful. For this example, the master sends the STXplus at address 01 a value of 85643. assuming that the format is set to 2(X.).

Request from Master	Response from STXplus	
>aaZ±ffffffssr	Ar	Format
>01Z85643.38r	A030r E	xample

‘V0’ Command – Version

This command is sent by the master to request the STXplus to send its version number in hex. For this example, the master requests the code from an STXplus at address 01, which returns a version of 01 hex and a checksum of 61.

Request from Master	Response from STXplus	
>aaV0ssr	Addrssr	Format
>01V0E7r	A0161r	Example

‘G0’ Command – Read Vessel Name

This command is sent by the master to request the STXplus to send its vessel name. The maximum number of characters for a vessel name is 10. The default value is “ ”. For this example, the master requests the vessel name from an STXplus at address 01, which returns “Gravel” and a checksum of 61.

Request from Master	Response from STXplus	
>aaG0ssr	A?????????ssr	Format
>01G0D8r	AGravel61r	Example

‘P0’ Command – Write Vessel Name

This command is sent by the master to set the STXplus vessel name. The maximum number of characters for a vessel name is 10. For this example, the master sends a vessel name of “Sand” to an STXplus at address 01.

Request from Master	Response from STXplus	
>aaP0?????????ssr	Ar	Format
>01P0Sand67r	Ar	Example

‘n1’ Command – Read Analog/Digital Mode Flag

This command is sent by the master to request the STXplus to send the analog/digital mode. The range of returned values is 0-1 where 0 for calibrated in analog mode or 1 for calibrated in digital mode. The default value is 0 (analog mode). For this example, the master requests the mode for an STXplus at address 01 which returns the mode of 1 (digital mode) and a checksum of 51.

Request from Master	Response from STXplus
>aan1ssr	A000000dssr Format
>01n100r	A000000151r Example

'm1' Command – Write Analog/Digital Mode Flag

This command is sent by the master to set the analog/digital mode of an STXplus. The range of acceptable values is 0-1 where 0 for calibrated in analog mode or 1 for calibrated in digital mode. For this example, the master sets the mode for an STXplus at address 01 to the mode of 0 (analog mode). Any of the 6 leading zeros may be omitted.

Request from Master	Response from STXplus
>aam1000000dssr	Ar Format
>01m102Fr	Ar Example

'n2' Command – Read Output Current Range

This command is sent by the master to request the STXplus to send the range of the current output. The range of returned values is 0-3 where 0 for 4-20mA, 1 for 0-20mA, 2 for 20-4mA, or 3 for 20-0mA. The default value is 0 (4-20mA). For this example, the master requests the current output range for an STXplus at address 01 which returns the range of 1 (0-20mA) and a checksum of 51.

Request from Master	Response from STXplus
>aan2ssr	A000000dssr Format
>01n200r	A000000151r Example

'm2' Command – Write Output Current Range

This command is sent by the master to set the current output range of an STXplus. The range of acceptable values is 0-3 where 0 for 4-20mA, 1 for 0-20mA, 2 for 20-4mA, or 3 for 20-0mA. For this example, the master sets the current output range for an STXplus at address 01 to the mode of 3 (20-0mA). Any of the 6 leading zeros may be omitted.

Request from Master	Response from STXplus
>aam2000000dssr	Ar Format
>01m2333r	Ar Example

'R1' Command – Read Digital Delta (Scale Factor) Counts

This command is sent by the master to request the STXplus to send the delta counts calibration value which would only be in effect when in digital mode. This would be the A/D counts delta required in order for a weight delta to occur. The default value is 8,388,607. The range of this value can be $\pm 8,388,607$. For this example, the master requests the digital delta counts for an STXplus at address 01 which returns 923475 counts and a checksum of 3E.

Request from Master	Response from STXplus
>aaR1ssr	A(-)dddddddssr Format
>01R1E4r	A9234753Er Example

‘w1’ Command – Write Digital Delta (Scale Factor) Counts

This command is sent by the master to set the delta counts calibration value of an STXplus which would only be in effect when in digital mode. This would be the A/D counts delta required in order for a weight delta to occur. The range of this value can be $\pm 8,388,607$. For this example, the master sets the digital delta counts for an STXplus at address 01 to 14865.

Request from Master	Response from STXplus
>aaw1(-)dddddddssr	Ar Format
>01w11486511r	Ar Example

‘R2’ Command – Read Digital Delta (Scale Factor) Weight

This command is sent by the master to request the STXplus to send the delta weight calibration value which would only be in effect when in digital mode. This would be the weight change that would occur if an A/D counts change of digital delta counts occurred. The range of this value can be between 1 and 2,147,483,647. The default value is 9999. For this example, the master requests the digital delta counts for an STXplus at address 01 assuming a format of 3(X.X), which returns 92347.5 engineering units and a checksum of 6C.

Request from Master	Response from STXplus
>aaR2ssr	A(-)ffffffssr Format
>01R2E5r	A92347.56Cr Example

‘w2’ Command – Write Digital Delta (Scale Factor) Weight

This command is sent by the master to set the delta weight calibration value of an STXplus which would only be in effect when in digital mode. This would be the weight change that would occur if an A/D counts change of digital delta counts occurred. The range of this value can be between 1 and 2,147,483,647. For this example, the master sets the digital delta counts for an STXplus at address 01 assuming a format of 2(X.) to 14865.

Request from Master	Response from STXplus
>aaw2(-)ffffffssr	Ar Format
>01w214865.40r	Ar Example

‘R3’ Command – Read Digital Zero Counts

This command is sent by the master to request the STXplus to send the zero counts calibration value which would only be in effect when in digital mode. This would be the A/D counts required in order for a zero weight to occur. The range of this value can be $\pm 8,388,607$. The default value is 0. For this example, the master requests the digital zero counts for an STXplus at address 01 which returns 23475 counts and a checksum of 05.

Request from Master	Response from STXplus
>aaR3ssr	A(-)dddddddssr Format
>01R3E6r	A2347505r Example

‘w3’ Command – Write Digital Zero Counts

This command is sent by the master to set the zero counts calibration value of an STXplus which

would only be in effect when in digital mode. This would be the A/D counts required in order for a zero weight to occur. The range of this value can be $\pm 8,388,607$. For this example, the master sets the digital zero counts for an STXplus at address 01 to 14865.

Request from Master	Response from STXplus
>aaw3(-)dddddddssr	Ar Format
>01w31486513r	Ar Example

'R4' Command – Read Digital Zero Weight

This command is sent by the master to request the STXplus to send the zero weight calibration value which would only be in effect when in digital mode. This would be the weight that was used to calculate/calibrate a digital zero counts. The range of this value can be $\pm 2,147,483,647$. The default value is 0. For this example, the master requests the digital zero weight for an STXplus at address 01 assuming a format of 3(X.X), which returns 347.5 engineering units and a checksum of 01.

Request from Master	Response from STXplus
>aaR4ssr	A(-)ffffffssr Format
>01R4E7r	A347.501r Example

'w4' Command – Write Digital Zero Weight

This command is sent by the master to set the zero weight calibration value of an STXplus which would only be in effect when in digital mode. This would force a re-calibration of the digital zero counts value based on the A/D counts currently being read applied to the zero weight value transmitted without changing the delta counts/delta weight slope. The range of this value can be $\pm 2,147,483,647$. For this example, the master sets the digital zero weight for an STXplus at address 01 assuming a format of 2(X.) to 14865.

Request from Master	Response from STXplus
>aaw4(-)ffffffssr	Ar Format
>01w414865.42r	Ar Example

'R5' Command – Read Digital High Span Counts

This command is sent by the master to request the STXplus to send the high span counts calibration value which would only be in effect when in digital mode. This would be the A/D counts paired with the digital high span weight that would serve as one point on the calibration slope line if in 2 point calibration mode. The range of this value can be $\pm 8,388,607$. The default value is 8,388,607. For this example, the master requests the digital high span counts for an STXplus at address 01 which returns 23475 counts and a checksum of 05.

Request from Master	Response from STXplus
>aaR5ssr	A(-)dddddddssr Format
>01R5E8r	A2347505r Example

'w5' Command – Write Digital High Span Counts

This command is sent by the master to set the high span counts calibration value of an STXplus

which would only be in effect when in digital mode. This would be the A/D counts required in order for a high span weight to occur. The result of this command if in 2-point calibration mode or following a “w7”, “w8” or “L” command in slope-intercept calibration mode will be a recalculation/calibration of the following 2 values. First, the digital delta counts value based on the difference between the digital high span counts value and the digital low span counts value. Secondly, the digital zero counts value based on the value in counts would occur when 0 weight is displayed. The range of this value can be $\pm 8,388,607$. For this example, the master sets the digital high span counts for an STXplus at address 01 to 14865.

Request from Master	Response from STXplus
>aaw5(-)dddddddssr	Ar Format
>01w51486515r	Ar Example

‘R6’ Command – Read Digital High Span Weight

This command is sent by the master to request the STXplus to send the high span weight calibration value which would only be in effect when in digital mode. This would be the weight that is paired with the digital high span counts that would serve as one point on the calibration slope line if in 2-point calibration mode. The range of this value can be $\pm 2,147,483,647$. The default value is 9999. For this example, the master requests the digital high span weight for an STXplus at address 01 assuming a format of 3(X.X), which returns 347.5 engineering units and a checksum of 01.

Request from Master	Response from STXplus
>aaR6ssr	A(-)ffffffssr Format
>01R6E9r	A347.501r Example

‘w6’ Command – Write Digital High Span Weight

This command is sent by the master to set the high span weight calibration value of an STXplus which would only be in effect when in digital mode. This would be the weight that is displayed when high span A/D counts is measured. The result of this command if in 2-point calibration mode or following a “w7”, “w8” or “L” command in slope-intercept calibration mode will be a recalculation/calibration of the following value. The digital delta weight value based on the difference between the digital high span weight value and the digital low span weight value. The range of this value can be $\pm 2,147,483,647$. For this example, the master sets the digital high span weight for an STXplus at address 01 assuming a format of 2(X.) to 14865.

Request from Master	Response from STXplus
>aaw6(-)ffffffssr	Ar Format
>01w614865.44r	Ar Example

‘R7’ Command – Read Digital Low Span Counts

This command is sent by the master to request the STXplus to send the low span counts calibration value which would only be in effect when in digital mode. This would be the A/D counts paired with the low span weight that would serve as one point on the calibration slope line if in 2 point calibration mode. The range of this value can be $\pm 8,388,607$. The default value is 0.

For this example, the master requests the digital zero counts for an STXplus at address 01 which returns 23475 counts and a checksum of 05.

Request from Master	Response from STXplus
>aaR7ssr	A(-)dddddddssr Format
>01R7EAr	A2347505r Example

‘w7’ Command – Write Digital Low Span Counts

This command is sent by the master to set the low span counts calibration value of an STXplus which would only be in effect when in digital mode. This would be the A/D counts required in order for a low span weight to occur. The result of this command if in 2 point calibration mode or following a “w5”, “w6” or “H” command in slope-intercept calibration mode will be a re-calculation/calibration of the following 2 values. First, the digital delta counts value based on the difference between the digital high span counts value and the digital low span counts value. Secondly, the digital zero counts value based on the value in counts would occur when 0 weight is displayed. The range of this value can be $\pm 8,388,607$. For this example, the master sets the digital low span counts for an STXplus at address 01 to 14865.

Request from Master	Response from STXplus
>aaw7(-)dddddddssr	Ar Format
>01w71486517r	Ar Example

‘R8’ Command – Read Digital Low Span Weight

This command is sent by the master to request the STXplus to send the low span weight calibration value which would only be in effect when in digital mode. This would be the weight that is paired with the digital high span counts that would serve as one point on the calibration slope line if in 2 point calibration mode. The range of this value can be $\pm 2,147,483,647$. The default value is 0. For this example, the master requests the digital low span weight for an STXplus at address 01 assuming a format of 3(X.X), which returns 347.5 engineering units and a checksum of EB.

Request from Master	Response from STXplus
>aaR8ssr	A(-)ffffffssr Format
>01R8EBr	A347.501r Example

‘w8’ Command – Write Digital Low Span Weight

This command is sent by the master to set the zero weight calibration value of an STXplus which would only be in effect when in digital mode. This would be the weight that is displayed when low span A/D counts is measured. The result of this command if in 2-point calibration mode or following a “w5”, “w6” or “H” command in slope-intercept calibration mode will be a recalculation/calibration of the following value. The digital delta weight value based on the difference between the digital high span weight value and the digital low span weight value. The range of this value can be $\pm 2,147,483,647$. For this example, the master sets the digital zero weight for an STXplus at address 01 assuming a format of 2(X.) to 14865.

Request from Master	Response from STXplus
>aaw8(-)ffffffssr	Ar Format
>01w814865.46r	Ar Example

‘RB’ Command – Read Analog Delta Counts

This command is sent by the master to request the STXplus to send the delta counts calibration value which is used to calibrate the current output engine. This would be the change in either A/D counts if operating in analog mode or the change in weight units if operating in digital mode (refer to commands “n1”/”m1” for analog/digital mode) required in order for the current output to change over the entire range that the current output is set to (refer to commands “n2”/”m2” for current output range). The range of this value can be between 1 and 8,388,607 in analog mode and between 1 and 2,147,483,647 in digital mode. The default value is 8,388,607. For this example, the master requests the analog delta counts for an STXplus at address 01 assumed to be in analog mode which returns 23475 counts and a checksum of F5.

Request from Master	Response from STXplus
>aaRBssr	A(-)ffffffssr Format
>01RBF5r	A2347505r Example

‘wB’ Command – Write Analog Delta Counts

This command is sent by the master to set the delta counts calibration value of an STXplus which is used to calibrate the current output engine. This would be the change in either A/D counts if operating in analog mode or the change in weight units if operating in digital mode (refer to commands “n1”/”m1” for analog/digital mode) required in order for the current output to change over the entire range that the current output is set to (refer to commands “n2”/”m2” for current output range). The result of this command will be to re-calculate/calibrate the current output high weight value (commands “R9/w9”) based on the sum of current output low weight and analog delta counts. The range of this value can be between 1 and 8,388,607 in analog mode and between 1 and 2,147,483,647 in digital mode. For this example, the master sets the analog delta counts for an STXplus at address 01 operating in digital mode assuming a format of 2(X.) to14865.

Request from Master	Response from STXplus
>aawB(-)ffffffssr	Ar Format
>01wB14865.50r	Ar Example

‘RC’ Command – Read Analog Zero Counts

This command is sent by the master to request the STXplus to send the zero counts calibration value which is used to calibrate the current output engine. This would be the minimum A/D counts if operating in analog mode or the minimum weight units if operating in digital mode (refer to commands “n1”/”m1” for analog/digital mode) where the lowest portion of the current output range would begin to change towards the highest portion of the current output range (refer to commands “n2”/”m2” for current output range). The range of this value can be ±8,388,607 in analog mode and ±2,147,483,647 in digital mode. The default value is 0. For this example, the master requests the analog zero counts for an STXplus at address 01 assumed to be in analog mode which returns 23475 counts and a checksum of F5.

Request from Master	Response from STXplus
>aaRCssr	A(-)ffffffssr Format
>01RCF6r	A2347505r Example

‘wC’ Command – Write Analog Zero Counts

This command is sent by the master to set the zero counts calibration value of an STXplus which is used to calibrate the current output engine. This would be the minimum A/D counts if operating in analog mode or the minimum weight units if operating in digital mode (refer to commands “n1”/”m1” for analog/digital mode) where the lowest portion of the current output range would begin to change towards the highest portion of the current output range (refer to commands “n2”/”m2” for current output range). The result of this command will be to re-calculate/calibrate the current output low weight value (commands “RA/wA”) based on the subtraction of current output high weight and analog delta counts. The range of this value can be $\pm 8,388,607$ in analog mode and $\pm 2,147,483,647$ in digital mode. For this example, the master sets the analog zero counts for an STXplus at address 01 assuming a format of 2(X.) to 14865.

Request from Master	Response from STXplus
>aawC(-)ffffffssr	Ar Format
>01wC14865.51r	Ar Example

‘RD’ Command – Read Tare Weight

This command is sent by the master to request the STXplus to send the tare weight value. This value would be the difference between gross weight and net weight. The range of this value can be $\pm 2,147,483,647$. The default value is 0. For this example, the master requests the tare weight for an STXplus at address 01 assuming a format of 3(X.X), which returns 347.5 engineering units and a checksum of EB.

Request from Master	Response from STXplus
>aaRDssr	A(-)ffffffssr Format
>01RDF7r	A347.501r Example

‘wD’ Command – Write Tare Weight

This command is sent by the master to set the tare weight value of an STXplus. This value would be the difference between gross weight and net weight. The range of this value can be $\pm 2,147,483,647$. For this example, the master sets the tare weight for an STXplus at address 01 assuming a format of 2(X.) to 14865.

Request from Master	Response from STXplus
>aawD(-)ffffffssr	Ar Format
>01wD14865.52r	Ar Example

‘aR’ Command – Read Averaging

This command is sent by the master to request the STXplus to send the averaging value. This value is the number of running A/D samples that would be averaged together to produce a filtered A/D output. The range of this value can be 0-100. The default value is 5. For this example,

the master requests the averaging value for an STXplus at address 01 which returns 34 and a checksum of 57.

Request from Master	Response from STXplus
>aaaRssr	A0000dddssr Format
>01aR14r	A000003457r Example

‘wR’ Command – Write Averaging

This command is sent by the master to set the averaging value of an STXplus. This value is the number of running A/D samples that would be averaged together to produce a filtered A/D output. The range of this value can be 0-100. For this example, the master sets the averaging for an STXplus at address 01 to 14. Any of the 4 leading zeros may be omitted.

Request from Master	Response from STXplus
>aawR0000dddssr	Ar Format
>01wR148Fr	Ar Example

‘n5’ Command – Read DSP Filter Enable

This command is sent by the master to request the STXplus to send the DSP Filter enabled state. The range of acceptable values is 0-1 where 0 for DSP Filter disabled or 1 for DSP Filter enabled. The default value is 1 (enabled). For this example, the master requests the DSP Filter enable state for an STXplus at address 01 which returns 1(enabled) and a checksum of 51.

Request from Master	Response from STXplus
>aan5ssr	A000000dssr Format
>01n504r	A000000151r Example

‘m5’ Command – Write DSP Filter Enable

This command is sent by the master to set the DSP Filter enabled state of an STXplus. The range of acceptable values is 0-1 where 0 for DSP Filter disabled or 1 for DSP Filter enabled. For this example, the master sets the DSP Filter enabled state for an STXplus at address 01 to 0 (disabled). Any of the 6 leading zeros may be omitted.

Request from Master	Response from STXplus
>aam5000000dssr	Ar Format
>01m5134r	Ar Example

‘RX’ Command – Read DSP Filter Factor

This command is sent by the master to request the STXplus to send the DSP Filter factor. The range of acceptable values is 1-100(%). The default value is 80(%). For this example, the master requests the DSP Filter factor for an STXplus at address 01 which returns 18(%) and a checksum of 59.

Request from Master	Response from STXplus	
>aaRXssr	A0000dddssr	Format
>01RX0Br	A000001859r	Example

'wX' Command – Write DSP Filter Factor

This command is sent by the master to set the DSP Filter factor of an STXplus. The range of acceptable values is 1-100(%). For this example, the master sets the DSP Filter factor for an STXplus at address 01 to 57(%). Any of the 4 leading zeros may be omitted.

Request from Master	Response from STXplus	
>aawX0000dddssr	Ar	Format
>01wX579Cr	Ar	Example

'RY' Command – Read DSP Filter Step

This command is sent by the master to request the STXplus to send the DSP Filter step. The range of this value can be between 0 and 2,147,483,647. The default value is 50. For this example, the master requests the DSP Filter step for an STXplus at address 01 assuming a format of 2(X.) which returns 1896. and a checksum of 06.

Request from Master	Response from STXplus	
>aaRYssr	Affffffssr	Format
>01RY0Cr	A1896.06r	Example

'wY' Command – Write DSP Filter Step

This command is sent by the master to set the DSP Filter step of an STXplus. The range of this value can be between 0 and 2,147,483,647. For this example, the master sets the DSP Filter step for an STXplus at address 01 assuming a format of 1(X00.) to 5700.

Request from Master	Response from STXplus	
>aawYffffffssr	Ar	Format
>01wY5700.2Br	Ar	Example

'RZ' Command – Read DSP Filter Qualify

This command is sent by the master to request the STXplus to send the DSP Filter qualify. The range of acceptable values is 2-20. The default value is 3. For this example, the master requests the DSP Filter qualify for an STXplus at address 01 which returns 10 and a checksum of 51.

Request from Master	Response from STXplus	
>aaRZssr	A00000ddssr	Format
>01RZ0Dr	A000001051r	Example

‘wZ’ Command – Write DSP Filter Qualify

This command is sent by the master to set the DSP Filter qualify of an STXplus. The range of acceptable values is 2-20. For this example, the master sets the DSP Filter qualify for an STXplus at address 01 to 15(%). Any of the 5 leading zeros may be omitted.

Request from Master	Response from STXplus
>aawZ00000ddssr	Ar Format
>01wZ1598r	Ar Example

‘[R1’ Command – Read 20mA Trim Value

This command is sent by the master to request the STXplus to send the 20mA trim value. The trim value is used to calibrate the current output engine at the 20mA point. The range of acceptable values is 0-65535. The default value is 59,674. For this example, the master requests the 20mA trim value for an STXplus at address 01 which returns 59611 and a checksum of 66.

Request from Master	Response from STXplus
>aa[R1ssr	A00ddddddssr Format
>01[R13Fr	A005961166r Example

‘[W1’ Command – Write 20mA Trim Value

This command is sent by the master to set the 20mA trim value of an STXplus. The trim value is used to calibrate the current output engine at the 20mA point. The range of acceptable values is 0-65535. For this example, the master sets the 20mA trim value for an STXplus at address 01 to 55789. Any of the 2 leading zeros may be omitted.

Request from Master	Response from STXplus
>aa[W100000ddssr	Ar Format
>01[W15578956r	Ar Example

‘[R2’ Command – Read 4mA Trim Value

This command is sent by the master to request the STXplus to send the 4mA trim value. The trim value is used to calibrate the current output engine at the 4mA point. The range of acceptable values is 0-65535. The default value is 11912. For this example, the master requests the 4mA trim value for an STXplus at address 01 which returns 19611 and a checksum of 62.

Request from Master	Response from STXplus
>aa[R2ssr	A00ddddddssr Format
>01[R240r	A001961162r Example

‘[W2’ Command – Write 4mA Trim Value

This command is sent by the master to set the 4mA trim value of an STXplus. The trim value is used to calibrate the current output engine at the 4mA point. The range of acceptable values is 0-65535. For this example, the master sets the 4mA trim value for an STXplus at address 01 to 15789. Any of the 2 leading zeros may be omitted.

Request from Master	Response from STXplus
>aa[W200000ddssr	Ar Format
>01[W21578973r	Ar Example

‘R3’ Command – Read 0mA Trim Value

This command is sent by the master to request the STXplus to send the 0mA trim value. The trim value is used to calibrate the current output engine at the 0mA point. The range of acceptable values is 0-65535. The default value is 0. For this example, the master requests the 0mA trim value for an STXplus at address 01 which returns 591 and a checksum of 5F.

Request from Master	Response from STXplus
>aa[R3ssr	A00dddddssr Format
>01[R341r	A00005915Fr Example

‘W3’ Command – Write 0mA Trim Value

This command is sent by the master to set the 0mA trim value of an STXplus. The trim value is used to calibrate the current output engine at the 0mA point. The range of acceptable values is 0-65535. For this example, the master sets the 0mA trim value for an STXplus at address 01 to 89. Any of the 2 leading zeros may be omitted.

Request from Master	Response from STXplus
>aa[W300000ddssr	Ar Format
>01[W389D7r	Ar Example

‘R9’ Command – Read Current Output High Weight

This command is sent by the master to request the STXplus to send the current output high weight calibration value. This would be the maximum A/D counts if operating in analog mode or the maximum weight units if operating in digital mode (refer to commands “n1”/”m1” for analog/digital mode) where the highest portion of the current output range would be obtained (refer to commands “n2”/”m2” for current output range). The range of this value can be $\pm 8,388,607$ in analog mode and $\pm 2,147,483,647$ in digital mode. The default value is 8,388,607. For this example, the master requests the current output high weight for an STXplus at address 01 assuming it is in digital mode and using a format of 3(X.X), which returns 347.5 engineering units and a checksum of EB.

Request from Master	Response from STXplus
>aaR9ssr	A(-)ffffffssr Format
>01R9ECr	A347.501r Example

‘w9’ Command – Write Current Output High Weight

This command is sent by the master to set the current output high weight calibration value of an STXplus. This would be the maximum A/D counts if operating in analog mode or the maximum weight units if operating in digital mode (refer to commands “n1”/”m1” for analog/digital mode) where the highest portion of the current output range would be obtained (refer to commands “n2”/”m2” for current output range). The range of this value can be $\pm 2,147,483,647$. For this

example, the master sets the current output high weight for an STXplus at address 01 assuming a format of 2(X.) to14865.

Request from Master	Response from STXplus
>aaw9(-)ffffffssr	Ar Format
>01w914865.47r	Ar Example

‘RA’ Command – Read Current Output Low Weight

This command is sent by the master to request the STXplus to send the current output low weight calibration value. This would be the minimum A/D counts if operating in analog mode or the minimum weight units if operating in digital mode (refer to commands “n1”/”m1” for analog/digital mode) where the lowest portion of the current output range would be obtained (refer to commands “n2”/”m2” for current output range). The range of this value can be $\pm 8,388,607$ in analog mode and $\pm 2,147,483,647$ in digital mode. The default value is 0. For this example, the master requests the current output low weight for an STXplus at address 01 assuming it is in digital mode and using a format of 3(X.X), which returns 347.5 engineering units and a checksum of EB.

Request from Master	Response from STXplus
>aaRAssr	A(-)ffffffssr Format
>01RAF4r	A347.501r Example

‘wA’ Command – Write Current Output Low Weight

This command is sent by the master to set the current output low weight calibration value of an STXplus. This would be the minimum A/D counts if operating in analog mode or the minimum weight units if operating in digital mode (refer to commands “n1”/”m1” for analog/digital mode) where the lowest portion of the current output range would be obtained (refer to commands “n2”/”m2” for current output range). The range of this value can be $\pm 2,147,483,647$. For this example, the master sets the current output low weight for an STXplus at address 01 assuming a format of 2(X.) to14865.

Request from Master	Response from STXplus
>aawA(-)ffffffssr	Ar Format
>01wA14865.4Fr	Ar Example

‘tH’ Command – Read Current Output Fail-safe Mode

This command is sent by the master to request the STXplus to send the current output fail-safe mode. The range of acceptable values is 0-2 where 0 for no change, 1 for minimum current output range, or 2 for maximum current range. The default value is 0 (no change). For this example, the master requests the current output failsafe mode for an STXplus at address 01 which returns 0 (no change) and a checksum of 51.

Request from Master	Response from STXplus
>aatHssr	A000000dssr Format
>01tH1Dr	A000000151r Example

'bH' Command – Write Current Output Fail-safe Mode

This command is sent by the master to set the current output failsafe mode of an STXplus. The range of acceptable values is 0-2 where 0 for no change, 1 for minimum current output range, or 2 for maximum current range. For this example, the master sets the current output fail-safe mode for an STXplus at address 01 to 1 (minimum current output range). Any of the 6 leading zeros may be omitted.

Request from Master	Response from STXplus
>aabH000000dssr	Ar Format
>01bH13Cr	Ar Example

'tI' Command – Read Current Output Test Mode

This command is sent by the master to request the STXplus to send the current output test mode. The range of acceptable values is 0-1 where 0 for test mode not enabled or 1 for test mode enabled. When test mode is enabled the current output value can be changed with command “bJ” otherwise it is a read only value. The default value is 0 (not enabled). For this example, the master requests the current output test mode for an STXplus at address 01 which returns 0 (not enabled) and a checksum of 50.

Request from Master	Response from STXplus
>aatlssr	A000000dssr Format
>01tI1Er	A000000050r Example

'bI' Command – Write Current Output Test Mode

This command is sent by the master to set the current output test mode of an STXplus. The range of acceptable values is 0-1 where 0 for test mode not enabled of 1 for test mode enabled. When test mode is enabled the current output value can be changed with command “bJ” otherwise it is a read only value. For this example, the master sets the current output test mode for an STXplus at address 01 to 1(enabled). Any of the 6 leading zeros may be omitted.

Request from Master	Response from STXplus
>aabI000000dssr	Ar Format
>01bI13Dr	Ar Example

'tG' Command – Read Current Output Tracking Mode

This command is sent by the master to request the STXplus to send the current output tracking mode. The range of acceptable values is 0-1 where 0 for current output tracks gross weight or 1 for current output tracks net weight. The default value is 0 (tracking gross). For this example, the master requests the current output tracking mode for an STXplus at address 01 which returns 0(tracking gross) and a checksum of 50.

Request from Master	Response from STXplus
>aatlssr	A000000dssr Format
>01tG1Cr	A000000050r Example

‘bG’ Command – Write Current Output Tracking Mode

This command is sent by the master to set the current output test mode of an STXplus. The range of acceptable values is 0-1 where 0 for current output tracks gross weight or 1 for current output tracks net weight. For this example, the master sets the current output tracking mode for an STXplus at address 01 to 1 (tracking net). Any of the 6 leading zeros may be omitted.

Request from Master	Response from STXplus
>aabG000000dssr	Ar Format
>01bG13Br	Ar Example

‘tJ’ Command – Read Current Output Value in Counts

This command is sent by the master to request the STXplus to send the current output value in counts. The range of acceptable values is 0-65535 where 0 corresponds to the minimum current output available and 65535 corresponds to the maximum current output available. For this example, the master requests the current output value for an STXplus at address 01 which returns 7843 and a checksum of 66.

Request from Master	Response from STXplus
>aatJssr	A00dddddssr Format
>01tJ1Cr	A000784366r Example

‘bJ’ Command – Write Current Output Value in Counts

This command is sent by the master to set the current output value of an STXplus. This can only be done if the current output test mode is enabled (see command “tl/bl”). The range of acceptable values is 0-65535 where 0 corresponds to the minimum current output available and 65535 corresponds to the maximum current output available. For this example, the master sets the current output value for an STXplus at address 01 to 11219 assuming that the test mode is enabled. Any of the leading zeros may be omitted.

Request from Master	Response from STXplus
>aabG00dddddssr	Ar Format
>01bG1121908r	Ar Example

‘GI’ Command – Read Setpoint Deadband Value

This command is sent by the master to request the STXplus to send the setpoint deadband value. Acceptable values for setpoint number is 1 and 2. The range of this value can be between 0 and 2,147,483,647. The default value is 10. For this example, the master requests setpoint 1’s deadband value for an STXplus at address 01 assuming it is using a format of 4(X.XX), which returns 347.51 engineering units and a checksum of 32.

Request from Master	Response from STXplus
>aaGIssr	A(-)ffffffssr Format
>01GI122r	A347.5132r Example

‘PI’ Command – Write Setpoint Deadband Value

This command is sent by the master to set the setpoint deadband value of an STXplus. Acceptable values for setpoint number is 1 and 2. The range of this value can be between 0 and 2,147,483,647. For this example, the master sets setpoint 2’s deadband value for an STXplus at address 01 to 1.1219 assuming it is using a format of 6(X.XXXX).

Request from Master	Response from STXplus
>aaPI(-)ffffffssr	Ar Format
>01PI21.121958r	Ar Example

‘G8’ Command – Read Setpoint Fail-safe Mode

This command is sent by the master to request the STXplus to send the setpoint fail-safe mode. Acceptable values for setpoint number is 1 and 2. The range of acceptable values is 0-2 where 0 is no change, 1 is setpoint off, or 2 is setpoint on. The default value is 0 (no change). For this example, the master requests setpoint 2’s fail-safe mode for an STXplus at address 01 which returns 0 (no change) and a checksum of 51.

Request from Master	Response from STXplus
>aaG8nssr	A000000dssr Format
>01G8212r	A000000151r Example

‘P8’ Command – Write Setpoint Fail-safe Mode

This command is sent by the master to set the setpoint failsafe mode of an STXplus. Acceptable values for setpoint number is 1 and 2. The range of acceptable values is 0-2 where 0 is no change, 1 is setpoint off, or 2 is setpoint on. For this example, the master sets setpoint 1’s fail-safe mode for an STXplus at address 01 to 1 (setpoint off). Any of the 6 leading zeros may be omitted.

Request from Master	Response from STXplus
>aaP8n000000dssr	Ar Format
>01P8114Br	Ar Example

‘G9’ Command – Read Setpoint High/Low Mode

This command is sent by the master to request the STXplus to send the setpoint high/low mode. Acceptable values for setpoint number is 1 and 2. The range of acceptable values is 0-1 where 0 is low mode or 1 is high mode. The default value is 0 (low mode). For this example, the master requests setpoint 1’s high/low mode for an STXplus at address 01 which returns 0 (low mode) and a checksum of 50.

Request from Master	Response from STXplus
>aaG9nssr	A000000dssr Format
>01G9112r	A000000050r Example

‘P9’ Command – Write Setpoint High/Low Mode

This command is sent by the master to set the setpoint high/low mode of an STXplus. Acceptable values for setpoint number is 1 and 2. The range of acceptable values is 0-1 where 0 is low mode or 1 is high mode. For this example, the master sets setpoint 2’s high/low mode for an STXplus at address 01 to 1 (high mode). Any of the 6 leading zeros may be omitted.

Request from Master	Response from STXplus
>aaP9n000000dssr	Ar Format
>01P9214Dr	Ar Example

‘G7’ Command – Read Setpoint Tracking Mode

This command is sent by the master to request the STXplus to send the setpoint tracking mode. Acceptable values for setpoint number is 1 and 2. The range of acceptable values is 0-1 where 0 is setpoint tracks gross weight or 1 is setpoint tracks net weight. The default value is 0 (tracking gross). For this example, the master requests setpoint 2’s tracking mode for an STXplus at address 01 which returns 0 (tracking gross) and a checksum of 50.

Request from Master	Response from STXplus
>aaG7nssr	A000000dssr Format
>01G7211r	A000000050r Example

‘P7’ Command – Write Setpoint Tracking Mode

This command is sent by the master to set the setpoint tracking mode of an STXplus. Acceptable values for setpoint number is 1 and 2. The range of acceptable values is 0-1 where for 0 the current output tracks gross weight or for 1 the current output tracks net weight. For this example, the master sets setpoint 1’s tracking mode for an STXplus at address 01 to 1(tracking net). Any of the 6 leading zeros may be omitted.

Request from Master	Response from STXplus
>aaP7n000000dssr	Ar Format
>01P7114Ar	Ar Example

‘Rg’ Command – Read Setpoint State

This command is sent by the master to request the STXplus to send the setpoint state. Acceptable values for setpoint number is 1 and 2. The range of acceptable values is 0-1 where 0 is setpoint off or 1 is setpoint on. The default value is 0 (setpoint off). For this example, the master requests setpoint 2’s state for an STXplus at address 01 which returns 0 (setpoint off) and a checksum of 50.

Request from Master	Response from STXplus
>aaRgnssr	A000000dssr Format
>01Rg24Cr	A000000050r Example

‘wg’ Command – Write Setpoint State

This command is sent by the master to set the setpoint state of an STXplus. This can only be accomplished if setpoint test is enabled (see command “GB/PB”). Acceptable values for setpoint number is 1 and 2. The range of acceptable values is 0-1 where 0 is setpoint off or 1 is setpoint on. For this example, the master sets setpoint 1’s state for an STXplus at address 01 to 1 (setpoint on). Any of the 6 leading zeros may be omitted.

Request from Master	Response from STXplus
>aawgn000000dssr	Ar Format
>01wg11A1r	Ar Example

‘GB’ Command – Read Setpoint Test Mode

This command is sent by the master to request the STXplus to send the setpoint test mode. Acceptable values for setpoint number is 1 and 2. The range of acceptable values is 0-1 where 0 is test mode disabled or 1 is test mode enabled. The default value is 1 (test mode enabled). For this example, the master requests setpoint 2’s test mode for an STXplus at address 01 which returns 0 (test mode disabled) and a checksum of 50.

Request from Master	Response from STXplus
>aaGTnssr	A000000dssr Format
>01GB21Cr	A000000050r Example

‘PB’ Command – Write Setpoint Test Mode

This command is sent by the master to set the setpoint test mode of an STXplus. Acceptable values for setpoint number is 1 and 2. The range of acceptable values is 0-1 where 0 is test mode disabled or 1 is test mode enabled. For this example, the master sets setpoint 1’s state for an STXplus at address 01 to 1 (test mode enabled). Any of the 6 leading zeros may be omitted.

Request from Master	Response from STXplus
>aaPBn000000dssr	Ar Format
>01PB1155r	Ar Example

‘GH’ Command – Read Setpoint Value

This command is sent by the master to request the STXplus to send the setpoint value. Acceptable values for setpoint number is 1 and 2. The range of this value can be $\pm 2,147,483,647$. The default value is 0. For this example, the master requests setpoint 1’s value for an STXplus at address 01 assuming it is using a format of 4(X.XX), which returns 347.51 engineering units and a checksum of 32.

Request from Master	Response from STXplus
>aaGHnssr	A(-)ffffffssr Format
>01GH121r	A347.5132r Example

‘PH’ Command – Write Setpoint Value

This command is sent by the master to set the setpoint value of an STXplus. Acceptable values for setpoint number is 1 and 2. The range of this value can be $\pm 2,147,483,647$. For this example, the master sets setpoint 2’s value for an STXplus at address 01 to 1.1219 assuming it is using a format of 6(X.XXXX).

Request from Master	Response from STXplus
>aaPHn(-)ffffffssr	Ar Format
>01PH21.121957r	Ar Example

‘GS’ Command – Read Raw/In Linearization Value

This command is sent by the master to request the STXplus to send the selected raw/in linearization value. Acceptable selected values is 0-4 corresponding to points 1-5. The range of this value can be between 0 and 2,147,483,647. The default values for points 1-5 are 0., 2500., 5000., 7500., and 9999., respectively. For this example, the master requests point 1’s raw/in linearization value for an STXplus at address 01 assuming it is using a format of 4(X.XX), which returns 347.51 engineering units and a checksum of 32.

Request from Master	Response from STXplus
>aaGSnssr	A(-)ffffffssr Format
>01GS12Cr	A347.5132r Example

‘PS’ Command – Write Raw/In Linearization Value

This command is sent by the master to set the raw/in linearization value of an STXplus. Acceptable selected values is 1-4 corresponding to points 2-5, remember that point 1 must be 0. The range of this value can be between 0 and 2,147,483,647. For this example, the master sets point 2’s raw/in linearization value for an STXplus at address 01 to 1.1219 assuming it is using a format of 6(X.XXXX).

Request from Master	Response from STXplus
>aaPSn(-)ffffffssr	Ar Format
>01PS21.121962r	Ar Example

‘GT’ Command – Read Corrected/Out Linearization Value

This command is sent by the master to request the STXplus to send the selected corrected/out linearization value. Acceptable selected values is 0-4 corresponding to points 1-5. The range of this value can be between 0 and 2,147,483,647. The default values for points 1-5 are 0., 2500., 5000., 7500., and 9999. respectively. For this example, the master requests point 1’s corrected/out linearization value for an STXplus at address 01 assuming it is using a format of 4(X.XX), which returns 347.51 engineering units and a checksum of 32.

Request from Master	Response from STXplus
>aaGTnssr	A(-)ffffffssr Format
>01GT12Dr	A347.5132r Example

'PT' Command – Write Corrected/Out Linearization Value

This command is sent by the master to set the corrected/out linearization value of an STXplus. Acceptable selected values is 1-4 corresponding to points 2-5, remember that point 1 must be 0. The range of this value can be between 0 and 2,147,483,647. For this example, the master sets point 2's corrected/out linearization value for an STXplus at address 01 to 1.1219 assuming it is using a format of 6(X.XXXX).

Request from Master	Response from STXplus
>aaPTn(-)ffffffssr	Ar Format
>01PT21.121963r	Ar Example

'n3' Command – Read Linearization Enable

This command is sent by the master to request the STXplus to send the linearization enable status. The range of acceptable values is 0-1 where 0 is disabled or 1 is enabled. The default value is 0 (disabled). For this example, the master requests linearization enable status for an STXplus at address 01 which returns 0 (disabled) and a checksum of 50.

Request from Master	Response from STXplus
>aan3ssr	A000000dssr Format
>01n302r	A000000050r Example

'm3' Command – Write Linearization Enable

This command is sent by the master to set the linearization enable status of an STXplus. The range of acceptable values is 0-1 where 0 is disabled or 1 is enabled. For this example, the master sets linearization enable status for an STXplus at address 01 to 1 (enabled). Any of the 6 leading zeros may be omitted.

Request from Master	Response from STXplus
>aam3000000dssr	Ar Format
>01m3132r	Ar Example

'K1' Command – Read AB-RIO PCB Present

This command is sent by the master to request the STXplus to send confirmation that the AB-RIO PCB has been detected. The range of acceptable values is 0-1 where 0 is not found or 1 is found. For this example, the master requests whether the AB-RIO PCB is present for an STXplus at address 01 which returns 0 (not found) and a checksum of 50.

Request from Master	Response from STXplus
>aaK1ssr	A000000dssr Format
>01K1DDr	A000000050r Example

'K2' Command – Read AB-RIO Baud Rate

This command is sent by the master to request the STXplus to send the AB-RIO baud rate. The range of acceptable values is 0-2 where 0 for 57.6K, 1 for 115.2K, or 2 for 230.4K. For this example, the master requests AB-RIO baud rate for an STXplus at address 01 which returns 0 (57.6K) and a checksum of 50.

Request from Master	Response from STXplus	
>aaK2ssr	A000000dssr	Format
>01K2DEr	A000000050r	Example

‘L2’ Command – Write AB-RIO Baud Rate

This command is sent by the master to set the AB-RIO baud rate of an STXplus. The range of acceptable values is 0-2 where 0 for 57.6K, 1 for 115.2K, or 2 for 230.4K. For this example, the master sets AB-RIO baud rate for an STXplus at address 01 to 1 (115.2K). Any of the 6 leading zeros may be omitted.

Request from Master	Response from STXplus	
>aaL2000000dssr	Ar	Format
>01L2110r	Ar	Example

‘K3’ Command – Read AB-RIO Address

This command is sent by the master to request the STXplus to send the AB-RIO address. The range of acceptable values is 0-255. For this example, the master requests AB-RIO address for an STXplus at address 01 which returns 57 and a checksum of 5C.

Request from Master	Response from STXplus	
>aaK3ssr	A0000dddssr	Format
>01K3DFr	A00000575Cr	Example

‘L3’ Command – Write AB-RIO Address

This command is sent by the master to set the AB-RIO address of an STXplus. The range of acceptable values is 0-255. For this example, the master sets AB-RIO address for an STXplus at address 01 to 12. Any of the leading zeros may be omitted.

Request from Master	Response from STXplus	
>aaL30000dddssr	Ar	Format
>01L31243r	Ar	Example

‘K4’ Command – Read AB-RIO Group

This command is sent by the master to request the STXplus to send the AB-RIO group. The range of acceptable values is 0-3 where 0 for Group 0, 1 for Group 2, 2 for Group 4, or 3 for Group 6. For this example, the master requests AB-RIO group for an STXplus at address 01 which returns 3 (Group 6) and a checksum of 53.

Request from Master	Response from STXplus	
>aaK4ssr	A000000dssr	Format
>01K4DEr	A000000353r	Example

‘L4’ Command – Write AB-RIO group

This command is sent by the master to set the AB-RIO group of an STXplus. The range of acceptable values is 0-3 where 0 for Group 0, 1 for Group 2, 2 for Group 4, or 3 for Group 6. For this example, the master sets AB-RIO group for an STXplus at address 01 to 1 (Group 2). Any of the 6 leading zeros may be omitted.

Request from Master	Response from STXplus
>aaL4000000dssr	Ar Format
>01L4112r	Ar Example

‘K5’ Command — Read AB-RIO Rack Size

This command is sent by the master to request the STXplus to send the AB-RIO rack size. The range of acceptable values is 0-3 where 0 for 1/4, 1 for 1/2, 2 for 3/4, or 3 for full. For this example, the master requests AB-RIO rack size for an STXplus at address 01 which returns 0 (1/4) and a checksum of 50.

Request from Master	Response from STXplus
>aaK5ssr	A000000dssr Format
>01K5E1r	A000000050r Example

‘L5’ Command — Write AB-RIO Rack Size

This command is sent by the master to set the AB-RIO rack size of an STXplus. The range of acceptable values is 0-3 where 0 for 1/4, 1 for 1/2, 2 for 3/4, or 3 for full. For this example, the master sets AB-RIO rack size for an STXplus at address 01 to 1 (1/2). Any of the 6 leading zeros may be omitted.

Request from Master	Response from STXplus
>aaL5000000dssr	Ar Format
>01L5113r	Ar Example

‘K6’ Command — Read AB-RIO Last Rack

This command is sent by the master to request the STXplus to send the AB-RIO last rack. The range of acceptable values is 0-1 where 0 is Yes or 1 is No. For this example, the master requests AB-RIO last rack for an STXplus at address 01 which returns 0 (No) and a checksum of 50.

Request from Master	Response from STXplus
>aaK6ssr	A000000dssr Format
>01K6E2r	A000000050r Example

‘L6’ Command — Write AB-RIO last rack

This command is sent by the master to set the AB-RIO last rack of an STXplus. The range of acceptable values is 0-1 where 0 is Yes or 1 is No. For this example, the master sets AB-RIO last rack for an STXplus at address 01 to 1 (Yes). Any of the 6 leading zeros may be omitted.

Request from Master	Response from STXplus
>aaL6000000dssr	Ar Format
>01L6114r	Ar Example

‘K7’ Command — Read AB-RIO Mode

This command is sent by the master to request the STXplus to send the AB-RIO mode. The range of acceptable values is 0-1 where 0 is Discrete or 1 is Block. For this example, the master requests AB-RIO mode for an STXplus at address 01 which returns 0 (Discrete) and a checksum of 50.

Request from Master	Response from STXplus	
>aaK7ssr	A000000dssr	Format
>01K7E3r	A000000050r	Example

‘L7’ Command – Write AB-RIO Mode

This command is sent by the master to set the AB-RIO mode of an STXplus. The range of acceptable values is 0-1 where 0 is Discrete or 1 is Block. For this example, the master sets AB-RIO mode for an STXplus at address 01 to 1(Block). Any of the 6 leading zeros may be omitted.

Request from Master	Response from STXplus	
>aaL7000000dssr	Ar	Format
>01L7115r	Ar	Example

‘K8’ Command – Read DeviceNet PCB Present

This command is sent by the master to request the STXplus to send confirmation that the DeviceNet PCB has been detected. The range of acceptable values is 0-1 where 0 is not found or 1 is found. For this example, the master requests whether the DeviceNet PCB is present for an STXplus at address 01 which returns 0 (not found) and a checksum of 50.

Request from Master	Response from STXplus	
>aaK1ssr	A000000dssr	Format
>01K8E4r	A000000050r	Example

‘K9’ Command – Read DeviceNet Address

This command is sent by the master to request the STXplus to send the DeviceNet address. The range of acceptable values is 0-63. For this example, the master requests DeviceNet address for an STXplus at address 01 which returns 57 and a checksum of 5C.

Request from Master	Response from STXplus	
>aaK9ssr	A00000ddssr	Format
>01K9E5r	A00000575Cr	Example

‘L9’ Command – Write DeviceNet Address

This command is sent by the master to set the DeviceNet address of an STXplus. The range of acceptable values is 0-63. For this example, the master sets DeviceNet address for an STXplus at address 01 to 12. Any of the leading zeros may be omitted.

Request from Master	Response from STXplus	
>aaL900000ddssr	Ar	Format
>01L91249r	Ar	Example

‘KA’ Command – Read DeviceNet Baud Rate

This command is sent by the master to request the STXplus to send the DeviceNet baud rate. The range of acceptable values is 0-2 where 0 for 125K, 1 for 250K, or 2 for 500K. For this example, the master requests DeviceNet baud rate for an STXplus at address 01 which returns 0 (125K) and a checksum of 50.

Request from Master	Response from STXplus
>aaKAssr	A000000dssr Format
>01KAEDr	A000000050r Example

‘LA’ Command – Write DeviceNet Baud Rate

This command is sent by the master to set the DeviceNet baud rate of an STXplus. The range of acceptable values is 0-2 where 0 for 125K, 1 for 250K, or 2 for 500K. For this example, the master sets DeviceNet baudrate for an STXplus at address 01 to 1 (250K). Any of the 6 leading zeros may be omitted.

Request from Master	Response from STXplus
>aaLA000000dssr	Ar Format
>01LA11Fr	Ar Example

‘KB’ Command – Read DeviceNet Serial Number

This command is sent by the master to request the STXplus to send confirmation that the DeviceNet serial number. The serial number will be a 4 character value. For this example, the master requests whether the DeviceNet serial number for an STXplus at address 01 which returns “1234” and a checksum of CA.

Request from Master	Response from STXplus
>aaKBssr	A????ssr Format
>01KBEEr	A1234CAr Example

‘KC’ Command – Read ProfiBus PCB Present

This command is sent by the master to request the STXplus to send confirmation that the ProfiBus PCB has been detected. The range of acceptable values is 0-1 where 0 for not found or 1 for found. For this example, the master requests whether the ProfiBus PCB is present for an STXplus at address 01 which returns 0 (not found) and a checksum of 50.

Request from Master	Response from STXplus
>aaKCssr	A000000dssr Format
>01KCEFr	A000000050r Example

‘KD’ Command – Read ProfiBus Address

This command is sent by the master to request the STXplus to send the ProfiBus address. The range of acceptable values is 0-255. For this example, the master requests ProfiBus address for an STXplus at address 01 which returns 57 and a checksum of 5C.

Request from Master	Response from STXplus
>aaKDssr	A0000dddssr Format
>01KDF0r	A00000575Cr Example

‘LD’ Command – Write ProfiBus Address

This command is sent by the master to set the ProfiBus address of an STXplus. The range of acceptable values is 0-255. For this example, the master sets ProfiBus address for an STXplus at address 01 to 12. Any of the leading zeros may be omitted.

Request from Master	Response from STXplus
>aaLD0000dddssr	Ar Format
>01LD1254r	Ar Example

‘RW’ Command – Read DSP Step Monitor Value

This command is sent by the master to request the STXplus to send the DSP step monitor value. The range of this value can be between 0 and 2,147,483,647. For this example, the master requests DSP step monitor value for an STXplus at address 01 assuming it is using a format of 4(X.XX), which returns 347.51 engineering units and a checksum of 32.

Request from Master	Response from STXplus
>aaRWnssr	A(-)ffffffssr Format
>01RW0Ar	A347.5132r Example

‘wW’ Command – Write DSP Step Monitor On/Off

This command is sent by the master to set the state of the DSP Step Monitor of an STXplus. The range of acceptable values is 0-1 where 0 for Off or 1 for On with a resetting of the DSP step monitor value. For this example, the master requests DSP step monitor state for an STXplus at address 01 to 1 (On), which returns a checksum of 32.

Request from Master	Response from STXplus
>aawWnssr	Ar Format
>01wW60r	Ar Example

‘e1’ Command – Read Serial Port 1 Baud Rate

This command is sent by the master to request the STXplus to send serial port 1’s baud rate. The range of acceptable values is 0-3 where 0 for 9600K, 1 for 19.2K, 2 for 38.4K, or 3 for 115.2K. The default value is 0 (9600). For this example, the master requests serial port 1’s baud rate for an STXplus at address 01 which returns 0 (9600) and a checksum of 50.

Request from Master	Response from STXplus
>aae1ssr	A000000dssr Format
>01e1F7r	A000000050r Example

‘g1’ Command – Write Serial Port 1 Baud Rate

This command is sent by the master to set the serial port 1’s baud rate of an STXplus. The range of acceptable values is 0-3 where 0 for 9600K, 1 for 19.2K, 2 for 38.4K, or 3 for 115.2K. For this example, the master sets serial port 1’s baud rate for an STXplus at address 01 to 1 (19.2K). Any of the 6 leading zeros may be omitted.

Request from Master	Response from STXplus
>aag1000000dssr	Ar Format
>01g112Ar	Ar Example

'g2' Command – Write Serial Port 1 Protocol

This command is sent by the master to set the serial port 1's protocol of an STXplus. The range of acceptable values is 0-1 where 0 for Kistler-Morse® protocol or 1 for Vorne remote display. Important if you change the protocol from Kistler-Morse® to Vorne with this command there will not be a serial command to return back to Kistler-Morse® protocol. The default value is 0 (Kistler-Morse®). For this example, the master sets serial port 1's protocol for an STXplus at address 01 to 1 (Vorne). Any of the 6 leading zeros may be omitted.

Request from Master	Response from STXplus
>aag2000000dssr	Ar Format
>01g212Br	Ar Example

'e3' Command – Read ModBus Port Baud Rate

This command is sent by the master to request the STXplus to send the ModBus port baud rate. The range of acceptable values is 0-3 where 0 for 9600K, 1 for 19.2K, 2 for 38.4K, or 3 for 115.2K. The default value is 3 (115.2K). For this example, the master requests ModBus port baud rate for an STXplus at address 01 which returns 0 (9600) and a checksum of 50.

Request from Master	Response from STXplus
>aae3ssr	A000000dssr Format
>01e3EDr	A000000050r Example

'g3' Command – Write ModBus port Baud Rate

This command is sent by the master to set the ModBus port baud rate of an STXplus. The range of acceptable values is 0-3 where 0 for 9600K, 1 for 19.2K, 2 for 38.4K, or 3 for 115.2K. For this example, the master sets ModBus port baud rate for an STXplus at address 01 to 3 (115.2K). Any of the 6 leading zeros may be omitted.

Request from Master	Response from STXplus
>aag3000000dssr	Ar Format
>01g332Er	Ar Example

APPENDIX C: MODBUS PROTOCOL SERIAL COMMANDS

INTRODUCTION

This appendix contains the serial commands and Modbus protocol syntax used for serial communications between the host or Master (PLC or PC, etc.) and the STXplus. Detailed explanations and examples of the commands are included. If any parameter or set of parameters that are transmitted by the master are outside of the acceptable range an 'N' will be transmitted back by the STXplus.

MODBUS IMPLEMENTATION

Modbus is a multipoint protocol. This means that one PC/PLC can communicate with multiple devices on the same communication line. Due to this a given device must have a unique ID with which to address it – a Modbus device address. A device's device address **MUST** be unique on a given communication network – duplicate addresses lead to bus collision. **Modbus Device addresses must lie in the range 1 to 247 (1 Byte)**. The Modbus Device supports broadcast addressing. On receiving a valid request from a PC/PLC with a valid device address, the device replies the PC/PLC with an appropriate frame. The Modbus Device supports exception response also.

Modbus is a request/reply protocol and offers services specified by function codes. The function indicates what kind of action to perform. The Modbus application protocol establishes the format of the request. The function code field of a Modbus data unit is coded in one byte. Valid codes are in the range of 1 ... 255 decimal (128 – 255 reserved for exception responses). When a message is sent the function code field tells what kind of action to perform. Function code "0" is not valid. Sub-function codes are added to some function codes to define multiple actions. The data field of messages sent contains additional information that can be used to take the action defined by the function code. This can include items like discrete and register addresses, the quantity of items to be handled, and the count of actual data bytes in the field. The data field may be nonexistent (of zero length) in certain kinds of requests. In this case the function code alone specifies the action. If no error occurs related to the Modbus function request the data field of a response from a server to a client contains the data requested. If an error related to the Modbus function request occurs, the field contains an exception code that the server application can use to determine the next action to be taken. For a normal response, the device simply echoes to the request the original function code. For an exception response, the server returns a code that is equivalent to the original function code with its most significant bit set to logic 1.

The Modbus error-checking field contains a 16-bit value (2 Bytes).

The error check value is the result of a Cyclical Redundancy Check calculation performed on the message contents. The CRC value is calculated by the transmitting device, which appends the CRC to the message. The receiving device recalculates a CRC during receipt of the message, and compares the calculated value to the actual value it received in the CRC field. If the two values are not equal, an error results.

The CRC is started by first preloading a 16-bit register to all 1's. Then a process begins of applying successive eight-bit bytes of the message to the current contents of the register. Only the eight bits of data in each character are used for generating the CRC. Start and stop bits, and the parity bit, do not apply to the CRC. During generation of the CRC, each eight-bit character is exclusive ORed with the register contents. Then the result is shifted in the direction of the least significant bit (LSB), with a zero filled into the most significant bit (MSB) position. The LSB is extracted and examined. If the LSB was a 1, the register is then exclusive ORed with a preset, fixed value. If the LSB was a 0, no exclusive OR takes place.

This process is repeated until eight shifts have been performed. After the last (eighth) shift, the next eight-bit byte is exclusive ORed with the register's current value, and the process repeats for eight more shifts as described above. The final contents of the register, after all the bytes of the message have been applied, is the CRC value. When the CRC is appended to the message, the low-order byte is appended first, followed by the high-order byte.

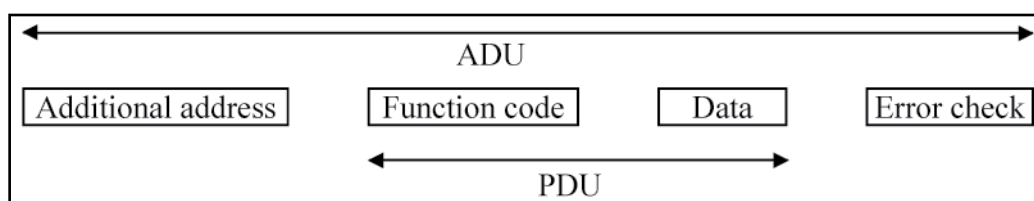

Modbus PDU for serial line communication = 256 - Server address (1 byte) - CRC (2bytes) = 253 bytes.

The Modbus protocol defines three PDUs. They are:

- Modbus Request PDU, mb_req_pdu
- Modbus Response PDU, mb_rsp_pdu
- Modbus Exception Response PDU, mb_excep_rsp_pdu
-

The mb_req_pdu is defined as: $mb_req_pdu = \{function_code, request_data\}$, where:
 function_code = [1 byte] Modbus function code corresponding to the desired Modbus function code or requested through the client API
 request_data = [n bytes] This field is function code dependent and usually contains information such as variable references, variable counts, data offsets, sub-function codes etc.

The mb_rsp_pdu is defined as:

$mb_rsp_pdu = \{function_code, response_data\}$, where:
 function_code = [1 byte] Modbus function code
 response_data = [n bytes] This field is function code dependent and usually contains information such as variable references, variable counts, data offsets, sub-function codes, etc.

For additional information on the Modbus protocol, refer to the “Modbus Application Protocol Specification “ which can be found on the www.modbus.org website.

MODBUS FUNCTION CODES**03 (0x03) Read Holding Registers**

This function code is used to read the contents of a contiguous block of holding registers in a remote device. The Request specifies the starting register address and the number of registers. The registers are addressed starting at zero. Therefore registers numbered 1-16 are addressed as 0-15. The register data in the response message are packed as two bytes per register, with the binary contents right justified within each byte. For each register, the first byte contains the high order bits and the second contains the low order bits.

Request

Function code: (1 Byte) 0x03

Starting Address: (2 Bytes) 0x0000 to 0xFFFF

Quantity of Registers: (2 Bytes) 1 to 125 (0x7D)

Response

Function code: (1 Byte) 0x03

Byte count: (1 Byte) 2 x N*

Register value: (N* x 2 Bytes)

*N = Quantity of Registers

Error

Error code: (1 Byte) 0x83

Exception code: (1 Byte) 01, 02, 03, or 04

16 (0x10) Write Multiple registers

This function code is used to write a block of contiguous registers (1 to approx. 120 registers) in a remote device. The requested written values are specified in the request data field. Data is packed as two bytes per register. The normal response returns the function code, starting address, and quantity of registers written.

Request

Function code: (1 Byte) 0x10

Starting Address: (2 Bytes) 0x0000 to 0xFFFF

Quantity of Registers: (2 Bytes) 0x0001 to 0x007B

Byte Count: (1 Byte) 2 x N*

Registers Value: (N* x 2 Bytes value)

*N = Quantity of Registers

Response

Function code: (1 Byte) 0x10

Starting Address: (2 Bytes) 0x0000 to 0xFFFF

Quantity of Registers: (2 Bytes) 1 to 123 (0x7B)

Error

Error code: (1 Byte) 0x90

Exception code: (1 Byte) 01, 02, 03, or 04

5 (0x05) Write Single Coil

This function code is used to write a single output to either ON or OFF in a remote device. The requested ON/OFF state is specified by a constant in the request data field. A value of FF 00 hex requests the output to be ON. A value of 00 00 requests it to be OFF. All other values are illegal and will not affect the output. The Request PDU specifies the address of the coil to be forced. Coils are addressed starting at zero. Therefore coil numbered 1 is addressed as 0. The requested ON/OFF state is specified by a constant in the Coil Value field. A value of 0xFF00 requests the coil to be ON. A value of 0X0000 requests the coil to be off. All other values are illegal and will not affect the coil. The normal response is an echo of the request, returned after the coil state has been written.

Request

Function code: (1 Byte) 0x05

Output Address: (2 Bytes) 0x0000 to 0xFFFF

Output Value: (2 Bytes) 0x0000 or 0xFF00

Response

Function code 1 Byte 0x05

Output Address 2 Bytes 0x0000 to 0xFFFF

Output Value 2 Bytes 0x0000 or 0xFF00

Error

Error code 1 Byte 0x85

Exception code 1 Byte 01 or 02 or 03 or 04

When a request is sent, a normal response is expected. One of four possible events can occur:

- If the device receives the request without a communication error, and can handle the query normally, it returns a normal response.
- If the device does not receive the request due to a communication error, no response is returned. A timeout condition will occur for the request.
- If the device receives the request, but detects a communication error (parity, CRC, ...), no response is returned. A timeout condition will occur for the request.
- If the device receives the request without a communication error, but cannot handle it, the device will return an exception response informing the client of the nature of the error.

MODBUS EXCEPTION RESPONSES

When a request is sent, a normal response is expected. One of four possible events can occur:

- If the device receives the request without a communication error, and can handle the query normally, it returns a normal response.
- If the device does not receive the request due to a communication error, no response is returned. A timeout condition will occur for the request.
- If the device receives the request, but detects a communication error (parity, CRC, ...), no response is returned. A timeout condition will occur for the request.
- If the device receives the request without a communication error, but cannot handle it, the device will return an exception response informing the client of the nature of the error.

The exception response message has two fields that differentiate it from a normal response:

Function Code Field: In a normal response, the device echoes the function code of the original request in the function code field of the response. All function codes have a most-significant bit (MSB) of 0 (their values are all below 80 hexadecimal). In an exception response, the device sets the MSB of the function code to 1. This makes the function code value in an exception response exactly 80 hexadecimal higher than the value would be for a normal response. With the function code's MSB set, the exception response can be recognized and the data field can be examined for the exception code.

Data Field: In a normal response, the device may return data or statistics in the data field (any information that was requested in the request). In an exception response, the device returns an exception code in the data field. This defines the device condition that caused the exception.

Modbus Exception Codes		
Code	Name	Meaning
01	ILLEGAL FUNCTION	The function code received in the query is not an allowable action for the device. This may be because the function code is only applicable to newer devices, and was not implemented in the unit selected. It could also indicate that the device is in the wrong state to process a request of this type.
02	ILLEGAL DATA ADDRESS	The data address received in the query is not an allowable address for the device. More specifically, the combination of reference number and transfer length is invalid.

Modbus Exception Codes		
Code	Name	Meaning
03	ILLEGAL DATA VALUE	A value contained in the query data field is not an allowable value for the device. This indicates a fault in the structure of the remainder of a complex request, such as that the implied length is incorrect. It specifically does NOT mean that a data item submitted for storage in a register has a value outside the expectation of the application program, since the Modbus protocol is unaware of the significance of any particular value of any particular register.
04	DEVICE FAILURE	An unrecoverable error occurred while the device was attempting to perform the requested action.
05	ACKNOWLEDGE	The device has accepted the request and is processing it, but a long duration of time will be required to do so. This response is returned to prevent a timeout error from occurring. A Poll Program Complete message can be issued to determine if processing is completed.
06	DEVICE BUSY	The device is engaged in processing a long-duration program command. The message should be retransmitted later when the device is free.

COMMANDS

Tare Request

Used to force a tare on the vessel.

Request for Tare Vessel			Response to Tare Vessel		
Position	Example	Meaning	Position	Example	Meaning
0	01	Device Address	0	01	Device Address
1	05	Force Action Func	1	05	Force Action Func
2	00	Action Add Hi	2	00	Action Add Hi
3	11	Action Add Lo	3	11	Action Add Lo
4	FF	Force Data Hi	4	FF	Force Data Hi
5	00	Force Data Lo	5	00	Force Data Lo
6		CRC	6		CRC
7			7		

The response is an echo of the query after the Action state has been forced.

Data 0xFF00 will force a tare to be performed.

Read a Register

Request for Read A Register			Response to Read A Register		
Position	Example	Meaning	Position	Example	Meaning
0	01	Device Address	0	01	Device Address
1	03	Read Function	1	03	Read Function
2	xx	Action Add Hi	2	00	02h Bytes Count
3	xx	Action Add Lo	3	11	High Byte
4	00	Word Count	4	FF	Lo Byte
5	01		CRC	13	
6		14			
7					

NOTE

Address xxxx must be a valid word address in the device or the device will respond with an error.

Write a Register

Request for a Write Register			Response to Write Register		
Position	Example	Meaning	Position	Example	Meaning
0	01	Device Address	0	01	Device Address
1	10	Write Function	1	10	Write Function
2	xx	Starting Add Hi	2	xx	Starting Add Hi
3	xx	Starting Add Lo	3	xx	Starting Add Lo
4	00	Word Count	4	00	Word Count
5	01		5	01	
6	02	Byte Count	6		CRC
7		high byte	7		
8		low byte			
11		CRC			
12					

NOTE

Address xxxx must be a valid word address in the device or the device will respond with an error. The word must not be a read-only word in the device.

IMPORTANT POINTS

All register values that are numeric are either 1 byte, 1 word, or 1 double-word integers. For those values that are floating point values you must read the format register to determine the placement of the decimal point then multiply or divide the integer by the appropriate magnitude of 10 in order to get the floating point value. The remaining registers that are character values have 2 characters / word where the high byte is the first character and the low byte is the second character.

Table C-1. Modbus Address Map.

Address	Variable	R/W	Acceptable values	Default State
0x0000	Device ID	R	15 - STXplus	15
0x0001	Device Status	R	0 - no error 1 - current output error	0
0x0002	4to20 Value	R/W - Only in test mode	0 - minimum 65535 - maximum	Indeterminate
0x0003	Setpoint 1 State	R/W - Only in test mode	0 - Off 1 - On	0
0x0004	Setpoint 2 State	R/W - Only in test mode	0 - Off 1 - On	0
0x0008	Full_Half_Bridge	R	0 - Half Bridge (12v excitation) 1 - Full Bridge (10v excitation)	Based on SW1
0x0010	Status	R	Bit 0 - ADC error Bit 1 - ADC over rng Bit 2 - ADC under rng Bit 7 - Eng Unit ovrflw Bit 8 - Gross negative Bit 9 - Net negative	Indeterminate
0x0011	Gross Wgt	R	±2,147,483,647	Indeterminate
0x0012				
0x0013	Net Wgt	R	±2,147,483,647	Indeterminate
0x0014				
0x0015	Tare Wgt: difference between Gross and Net	R	±2,147,483,647	Indeterminate
0x0016				
0x0017	Filtered A/D Cnts	R	±8,388,607	Indeterminate
0x0018				
0x0020	Firmware Version	R	numeric string - 0000.00000 (Major revision. Minor revision)	Based on version
0x0021				
0x0022				
0x0023				
0x0024				
0x0025				
0x0026				
0x0027				
0x0028				
0x0029				
0x0030	I4to20_Mode (range)	R/W	0 - 4-20 mA 1 - 0-20 mA 2 - 20-4 mA 3 - 20-0 mA	0
0x0031	I4to20_Track	R/W	0 - tracks Gross 1 - tracks Net	0
0x0032	I4to20_FS (failsafe)	R/W	0 - No change 1 - minimum range 2 - maximum range	0
0x0033	DAC_Cnts_20	R/W	0-65535	59674
0x0034	DAC_Cnts_04	R/W	0-65535	11912
0x0035	DAC_Cnts_00	R/W	0-65535	0
0x0036	ADC_Cts_1	R/W	±8,388,607 in analog mode ±2,147,483,647 in digital mode see addr. 0x114	0
0x0037				

APPENDIX C: MODBUS PROTOCOL SERIAL COMMANDS

Table C-1. Modbus Address Map. (continued)

Address	Variable	R/W	Acceptable values	Default State
0x0038	ADC_Cts_2	R/W	±8,388,607 in analog mode ±2,147,483,647 in digital mode see addr. 0x114	8,388,607 (0x7FFFFFF)
0x0039				
0x003A	DAC_Cts_1	R/W	0-65535	11912
0x003B	DAC_Cts_2	R/W	0-65535	59674
0x003D	DAC_Test	R/W	0 - disabled 1- enabled	0
0x0040	AB Present	R	0 - absent 1- present	Indeterminate
0x0041	AB Mode	R/W	0 - discrete 1- block	Indeterminate
0x0042	AB Address	R/W	0-255	Indeterminate
0x0043	AB Rack Size	R/W	0 - 1/4 1 - 1/2 2 - 3/4 3 - Full	Indeterminate
0x0044	AB Last Rack	R/W	0 - Yes 1 - No	Indeterminate
0x0045	AB Group	R/W	0 - 2 1 - 4 2 - 6 3 - 8	Indeterminate
0x0046	AB Baud	R/W	0 - 57.6K 1 - 115.2K 2 - 230.4K	Indeterminate
0x0048	DeviceNet Present	R	0 - absent 1- present	Indeterminate
0x0049	DeviceNet ID	R/W	0-63	Indeterminate
0x004A	DeviceNet Baud	R/W	0 - 125K 1 - 250K 2 - 500K	Indeterminate
0x004B	DeviceNet SN	R	4 characters	Indeterminate
0x004C				
0x004E	Profibus Present	R	0 - absent 1- present	Indeterminate
0x004F	Profibus Address	R/W	0-255	Indeterminate
0x0050	Raw Lin Pt 1	R	0 - 2,147,483,647	0
0x0051				
0x0052	Corrected Lin Pt 1	R	0 - 2,147,483,647	0
0x0053				
0x0054	Raw Lin Pt 2	R/W	0 - 2,147,483,647	2500
0x0055				
0x0056	Corrected Lin Pt 2	R/W	0 - 2,147,483,647	2500
0x0057				
0x0058	Raw Lin Pt 3	R/W	0 - 2,147,483,647	5000
0x0059				
0x005A	Corrected Lin Pt 3	R/W	0 - 2,147,483,647	5000
0x005B				
0x005C	Raw Lin Pt 4	R/W	0 - 2,147,483,647	7500
0x005D				
0x005E	Corrected Lin Pt 4	R/W	0 - 2,147,483,647	7500
0x005F				

Table C-1. Modbus Address Map. (continued)

Address	Variable	R/W	Acceptable values	Default State
0x0060	Raw Lin Pt 5	R/W	0 - 2,147,483,647	9999
0x0061				
0x0062	Corrected Lin Pt 5	R/W	0 - 2,147,483,647	9999
0x0063				
0x0064	Linearization Enable	R/W	0 - disabled 1 - enabled	0
0x0068- 0x007F	Reserved			
0x0080	Sp1_Value	R/W	±2,147,483,647	0
0x0081				
0x0082	Sp1_Deadband	R/W	0 - 2,147,483,647	10
0x0083				
0x0084	Sp1_PreAct	R/W	0 - 2,147,483,647	0
0x0085				
0x0086	Sp1_Hi_Lo	R/W	0 - low 1 - high	0
0x0087	Sp1_Net_Gross	R/W	0 - tracks Gross 1 - tracks Net	0
0x0088	Sp1_Failsafe	R/W	0 - No change 1 - setpoint off 2 - setpoint on	0
0x008A	SP1_Test	R/W	0 - disabled 1 - enabled	1
0x0090	Sp2_Value	R/W	±2,147,483,647	0
0x0091				
0x0092	Sp2_Deadband	R/W	0 - 2,147,483,647	10
0x0093				
0x0094	Sp2_PreAct	R/W	0 - 2,147,483,647	0
0x0095				
0x0096	Sp2_Hi_Lo	R/W	0 - low 1 - high	0
0x0097	Sp2_Net_Gross	R/W	0 - tracks Gross 1 - tracks Net	0
0x0098	Sp2_Failsafe	R/W	0 - No change 1 - setpoint off 2 - setpoint on	0
0x009A	SP2_Test	R/W	0 - disabled 1 - enabled	1
0x009F	ADC_Gain_Sel	R/W	1, 2, 4, 8, 16, 32, 64, 128	4 - Half Bridge (SW1) 32 - Full Bridge (SW1)
0x00A0	ADC_Res_Bits	R	19, 20, 21, 22, 23	20 - Half Bridge (SW1) 19 - Full Bridge (SW1)
0x00A1	AD_Update_Rate	R/W	4, 8, 16, 32, 64	64
0x00A2	ADC Channels Active	R/W	Bit 0 - Channel 1: 1 - On / 0 - Off Bit 1 - Channel 2: 1 - On / 0 - Off Bit 2 - Channel 3: 1 - On / 0 - Off Bit 3 - Channel 4: 1 - On / 0 - Off Bit 4-7- Reserved	1
0x00A3	ADC Channels Ghosted	R/W	Bit 0 - Channel 1: 1 - On / 0 - Off Bit 1 - Channel 2: 1 - On / 0 - Off Bit 2 - Channel 3: 1 - On / 0 - Off Bit 3 - Channel 4: 1 - On / 0 - Off	0
0x00A4	Channel 1 Ghosted Percentage	R/W	0-100	100

APPENDIX C: MODBUS PROTOCOL SERIAL COMMANDS

Table C-1. Modbus Address Map. (continued)

Address	Variable	R/W	Acceptable values	Default State
0x00A5	Channel 2 Ghosted Percentage	R/W	0-100	100
0x00A6	Channel 3 Ghosted Percentage	R/W	0-100	100
0x00A7	Channel 4 Ghosted Percentage	R/W	0-100	100
0x00B0	Vnet_Baud	R/W	1 - 9600 2 - 19.2 K 3 - 38.4 K 4 - 115.2 K	4
0x00B1	KM_disp_sel.	R/W	0 - KM Mode 1 - Vorne remote disp	0
0x00B2	Aux_Baud	R/W	1 - 9600 2 - 19.2 K 3 - 38.4 K 4 - 115.2 K	1
0x00C0	Device Name	R/W	10 character string	" "
0x00C1				
0x00C2				
0x00C3				
0x00C4				
0x00D0-0x00E1	Reserved			
0x0100	Zero Cnts	R/W	±8,388,607	0
0x0101				
0x0102	Low Span Cnts	R/W	±8,388,607	0
0x0103				
0x0104	High Span Cnts	R/W	±8,388,607	8,388,607 (0x7FFFFFF)
0x0105				
0x0106	Delta Cnts	R/W	1 - 8,388,607	8,388,607 (0x7FFFFFF)
0x0107				
0x0108	Low Span Wgt	R/W	±2,147,483,647	0
0x0109				
0x010A	High Span Wgt	R/W	±2,147,483,647	9999
0x010B				
0x010C	Delta Wgt	R/W	1 - 2,147,483,647	9999
0x010D				
0x010E	Zero Wgt	R/W	±2,147,483,647	0
0x010F				
0x0110	Units	R/W	4 character string	" "
0x0111				
0x0112	Wgt Format	R/W	0 - X00. 1 - X0. 2 - X. 3 - X.X 4 - X.XX 5 - X.XXX 6 - X.XXXX 7 - X.XXXXX	2
0x0113	Gross/Net Flag	R/W	0 - display Gross 1 - display Net	0

Table C-1. Modbus Address Map. (continued)

Address	Variable	R/W	Acceptable values	Default State
0x0114	DAC_CAL_Mode	R/W	Bit 0 - low span value entered in analog mode Bit 1 - high span value entered in analog mode Bit 2 - delta value entered in analog mode Bit 3 - zero value entered in analog mode Bit 4 - analog calibration attempted on STXplus via buttons while in digital cal mode. Bit 5 - STXplus Host acknowledged bit 4 was set. Bit 6 - calibraion constants are all defaults. Bit 7 - 1 = analog, 0 = digital calibration mode.	195 (0xC3)
0x0115	Calib_Mode	R/W	Bit 0 - Low span value entered Bit 1 - High span value entered Bit 2 - point to point calibration mode Bit 3 - slope intercept calibration mode	7
0x0120	Basic Avg Steps	R/W	0-100	5
0x0121	DSP Enable	R/W	0 - disabled 1 - enabled	1
0x0122	DSP Factor	R/W	1-100	80
0x0123	DSP Qualify	R/W	2-20	3
0x0124	DSP Step	R/W	0 - 2,147,483,647	50
0x0125				
0x0126	Step Monitor State	R/W	0 - Off 1 - On	0
0x0127	Step Monitor Val 0 - 2,147,483,647	R	0 - 2,147,483,647	Indeterminate
0x0128				
0x0131	Vessel Name	R/W	10 character string	Indeterminate
0x0132				
0x0133				
0x0134				
0x0135				

APPENDIX D: TECHNICAL DRAWINGS

This appendix contains the following technical drawings for the STXplus signal processor:

DRAWING NUMBER	TITLE
TI-SP.STXP-01	Model STXplus Enclosure/Boardset Installation Dimensions
TI.SP.STXP-02	Model STXplus Interconnect Diagram

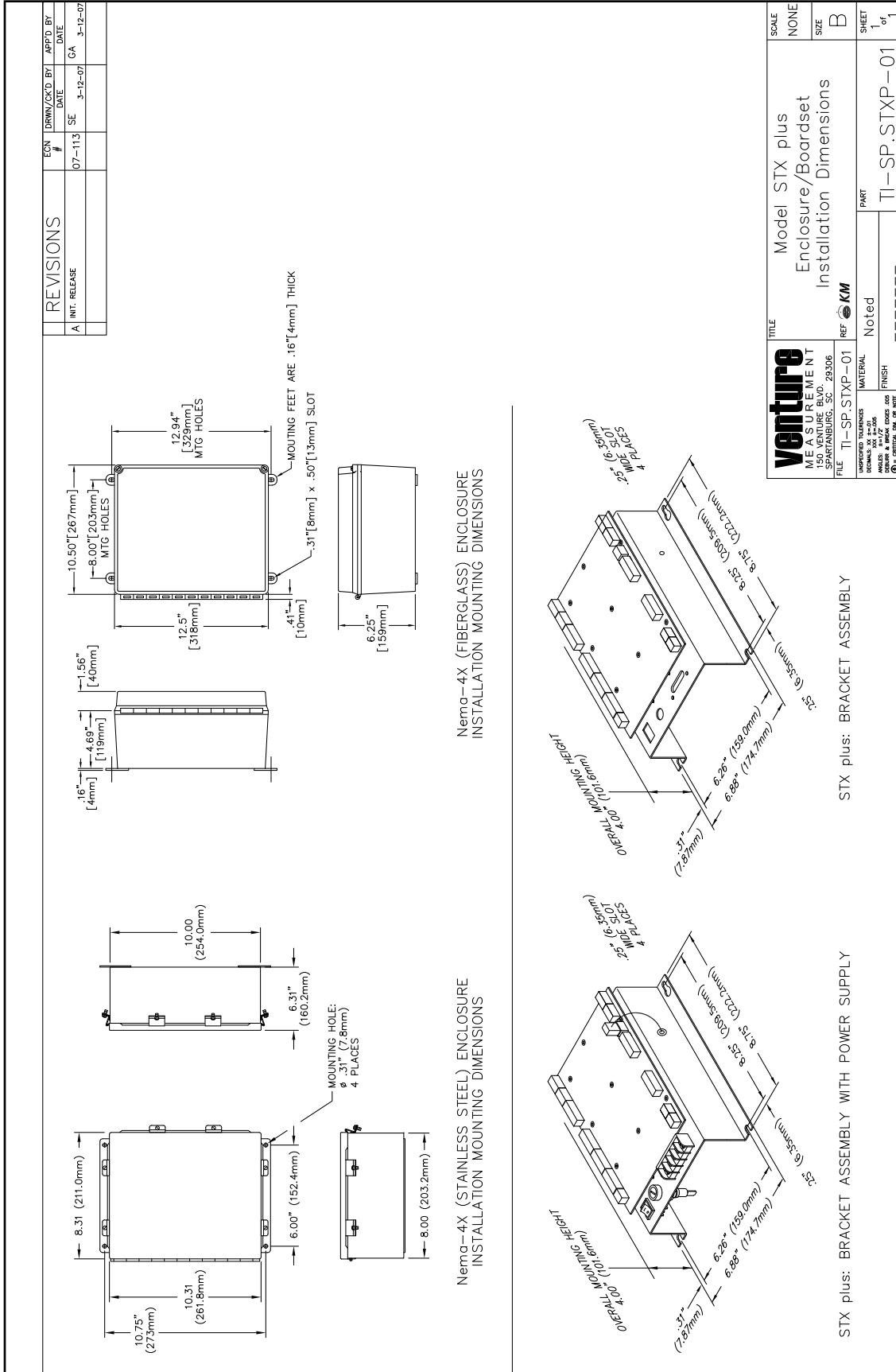

REV	DATE	BY	CHKD BY	DATE	REVISED FOR
A	07-11-07	SE	GA	3-12-07	INT. RELEASE
B	07-11-07	SE	GA	3-13-07	REVISED, NEW PCB DESIGN
C	07-11-07	SE	GA	11-16-07	ADDED REMOTE DISPLAY CONNECTION WISC. CORRECTIONS

NOTES: (UNLESS OTHERWISE SPECIFIED)

1. ALL WIRING SHOWN (LABELED) IS CUSTOMER INSTALLED.
2. ROUTE ALL AC WIRING SEPARATE FROM ALL OTHER WIRING.
3. THE ANALOG OUTPUT CABLE TYPE AND GAGE DEPENDS ON THE ENVIRONMENT, AND THE ANALOG INPUT CABLE TYPE DEPENDS ON THE TYPE OF SIGNAL. IT IS SUGGESTED WHEN RUNNING WITH OTHER SIGNAL WIRES IN TRAYS OR CONDUIT AND/OR IN ELECTRICAL NOISY AREAS. A BRAIDED SHIELD IS SUGGESTED WHEN PULLING LONG CABLE RUNS THROUGH CONDUIT OR WITH OTHER SIGNAL WIRES. GROUND THE SHIELD ONLY AT THE DEVICE RECEIVING THE ANALOG SIGNAL. TWISTED PAIR CABLE IS SUGGESTED FOR LOW ELECTRICAL NOISE AREAS.
4. SUGGESTED JACKETED CABLE TYPES:
18-AWG FOIL SHIELD TWISTED PAIR, BELDEN No. 8760 OR EQUIVALENT
18-AWG SPIRAL WRAPPED TWISTED PAIR.
5. THE 0-20/4-20 CURRENT TRANSMITTER IS POWERED BY THE STX plus POWER SUPPLY. THE CURRENT LOOP SIGNALS REQUIRE A POWER SUPPLY. REFER TO THE CURRENT LOOP WIRE LIST FOR THE "Loop Power" POSITION. THE MAXIMUM VOLTAGE THAT MAY BE APPLIED TO THIS INPUT IS 36 VDC.
6. FOR 4-WIRE CONNECTION, "J11" AND "J12" MUST BE IN THE SENSE INT POSITION.
7. WHEN USING SERIAL COMMUNICATIONS, POSITIONING "SW3" AND "SW4" TO "SERIAL" POSITION IS REQUIRED. REFER TO THE SERIAL COMMUNICATIONS CHAPTER OF THE OPERATORS MANUAL WHEN SETTING THE ADDRESS.
8. TYPICAL CABLE FOR FULL-BRIDGE SENSORS:
FOR 4-WIRE FULL-BRIDGE FOIL GAGE LOAD CELL TRANSDUCERS, USE 20-AWG, 4-CONDUCTOR SHIELDED CABLE. MAXIMUM CABLE LENGTH IS 50ft (15.2m). REFER TO LOAD CELL MANUFACTURER FOR THEIR RECOMMENDED CABLE TYPE, COLOR CODE AND MAXIMUM CABLE DISTANCES OR USE BELDEN 8723.
FOR 6-WIRE FULL-BRIDGE FOIL GAGE LOAD CELL TRANSDUCERS, USE 18-AWG, 6-CONDUCTOR SHIELDED CABLE. MAXIMUM CABLE LENGTH IS 50ft (15.2m). REFER TO LOAD CELL MANUFACTURER FOR THEIR RECOMMENDED CABLE TYPE, COLOR CODE AND MAXIMUM CABLE DISTANCES.
9. FOR TRANSDUCER/SIGNAL PROCESSOR SEPARATION DISTANCES UP TO 1,000 FEET, USE 18-AWG, 4-CONDUCTOR SHIELDED CABLE. MAXIMUM CABLE LENGTH IS 1,000 FEET. REFER TO LOAD CELL MANUFACTURER FOR EQUIVALENT AT INTERCONNECT JUNCTION BOXES AND THE MODEL STX plus DISTANCES UP TO 2,000 FEET REQUIRES 16-AWG, THREE-CONDUCTOR SHIELDED CABLE. (BELDEN 8618 OR EQUIVALENT) AS THE INTERCONNECT SIGNAL CABLE.
10. TO PREVENT GROUND LOOPS, CONNECT SIGNAL WIRE SHIELDS AT ONE END ONLY.
11. CABLE TYPE: BELDEN 9368 OR EQUIVALENT. MAXIMUM SEPARATION BETWEEN STX plus AND BARRIER IS 100ft (30.5 METERS).

SCALE	NONE
TITLE	Model STXplus Interconnect Diagram
MEASUREMENT SYSTEM	INCHES
DATE	07-11-07
FILE	TI-SP.STXP-02
REF	KM
NOTED	Noted
MATERIAL	FRESH
FINISH	FRESH
PART	TI-SP.STXP-02

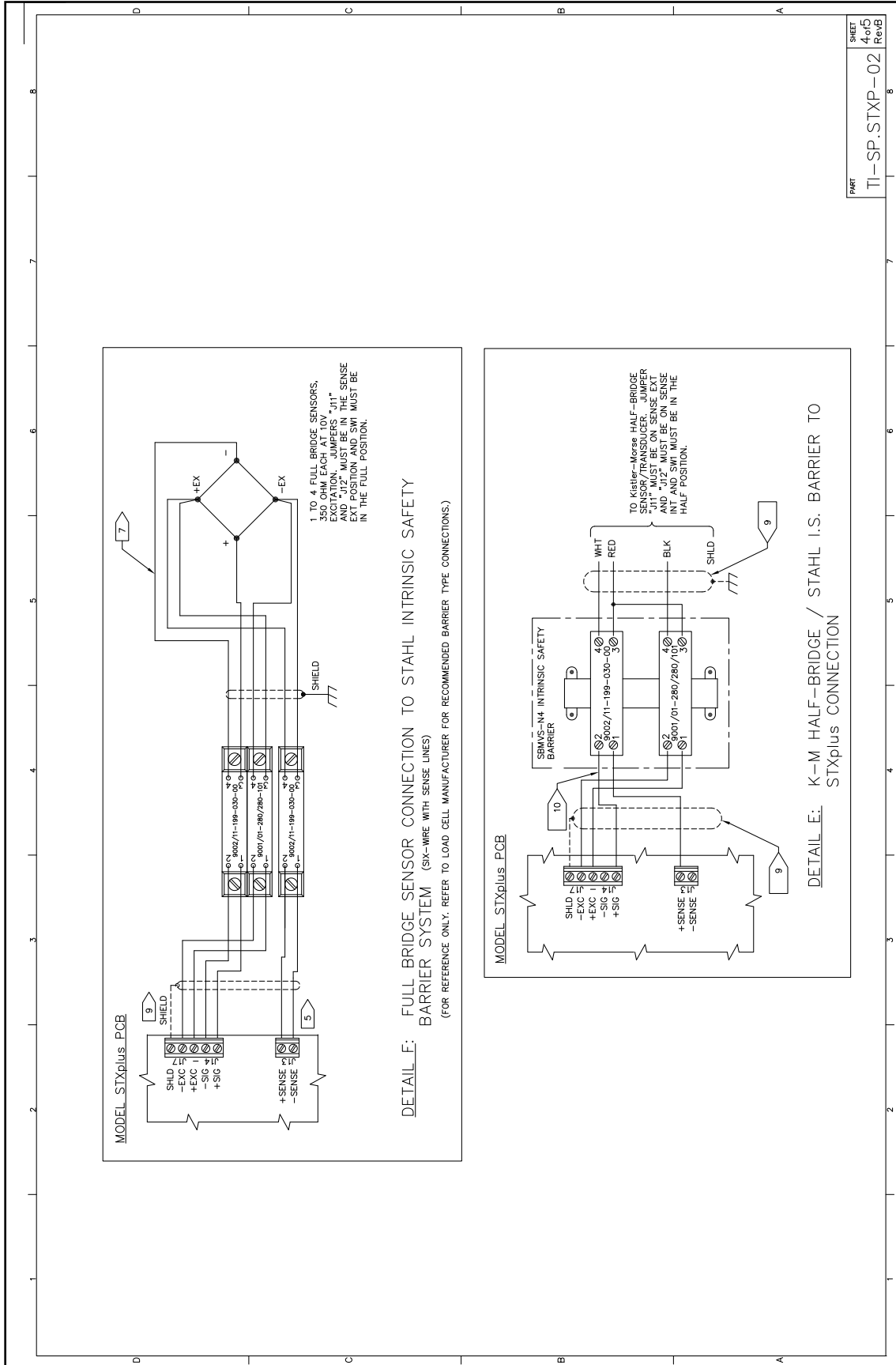

SHEET	4 of 6
RevB	
PART	TI-SP-STXP-02

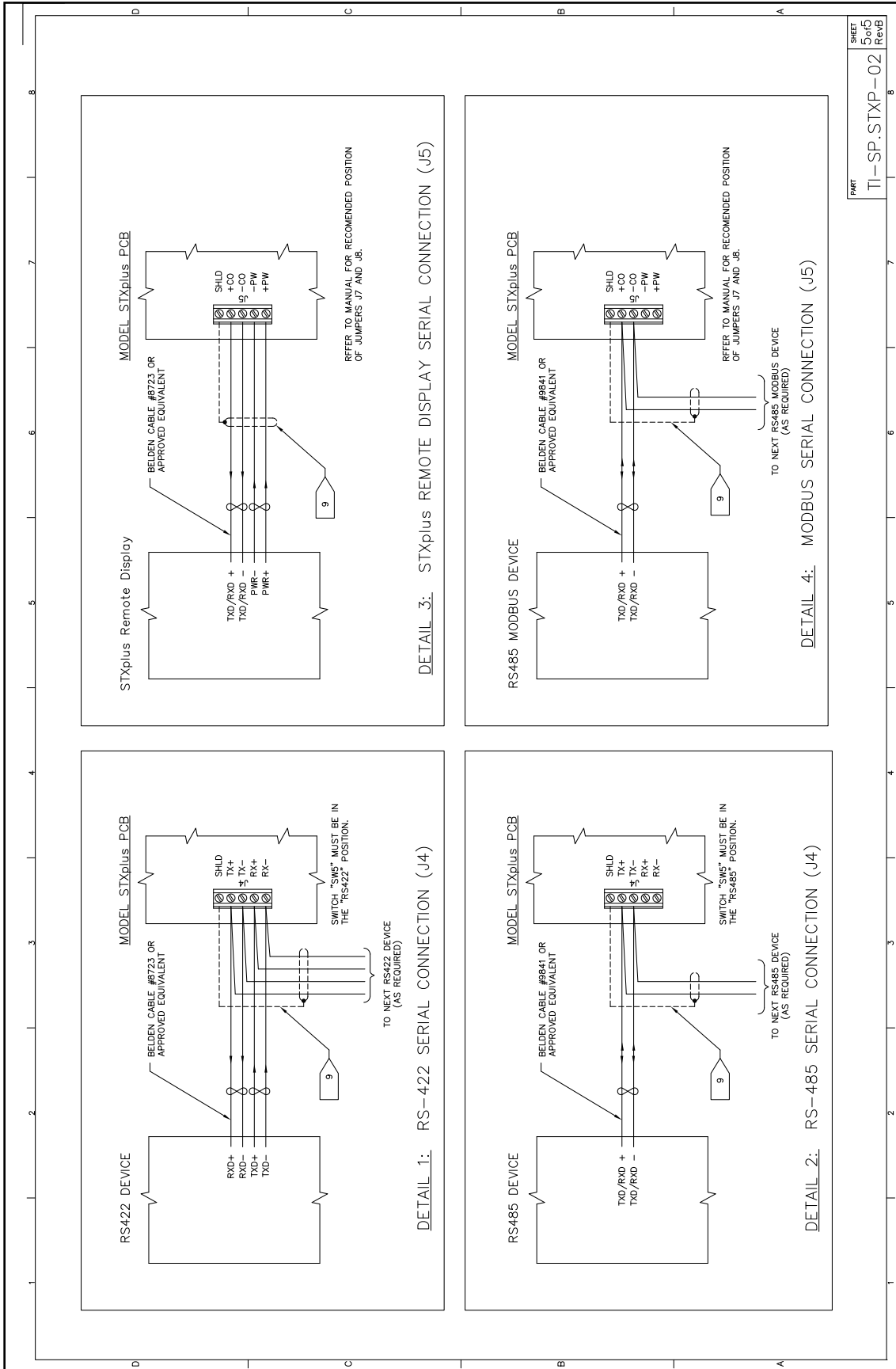

SHEET
5 of 5
RevB

PART
TI-SP.STXP-02

REVISIONS					
REV	Description	ECN	Checked	Approved	Date
A	Initial Release	10-229			5-19-10

Installation Instructions For AC Line Varistors

Shipped along with your STXplus you will find a small plastic bag with 3 Varistors. These devices must be installed on the incoming AC line that feeds the AC-DC power supply that supplies the DC power to the STXplus. If the incoming AC power is in excess of 300VAC then contact the factory for a replacement set of Varistors that will meet your special needs.

You will install one between L1 and L2, one between L1 and ground, and one between L2 and ground.

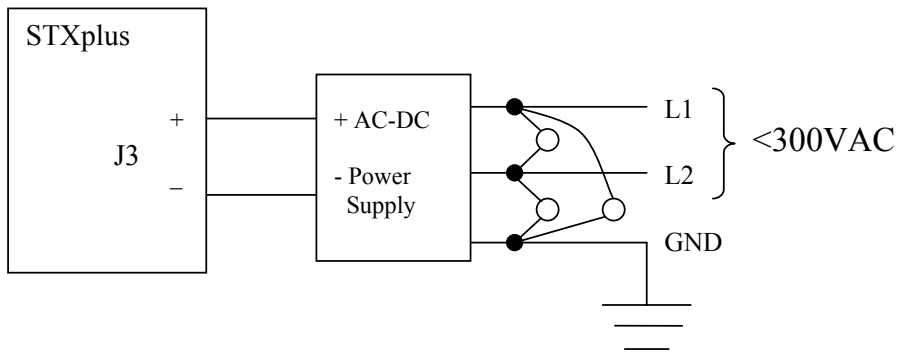

Approvals	Date			
		 150 Venture Blvd. Spartanburg, SC 29306	Customer Drawing	
			Title: Customer Installed Varistor Instructions	
		Ref: 		
		P/N: TI-STXPlus.Varistor	Sheet 1 of 1	REV A

NOTES

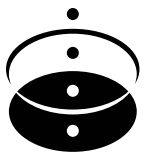

KM **KISTLER-MORSE**
Measure of Success

150 Venture Boulevard
Spartanburg, SC 29306
800.426.9010 [Toll Free]
864.574.2763 [Phone]
864.574.8063 [Fax]
www.kistlermorse.com
sales@kistlermorse.com

All rights reserved.
All data subject to change without notice.

97-1180-01
Revision F
October 2011