

hydra-wave  
Intrinsically-Safe  
Medium Range  
Ultrasonic Level Transmitter



◆ CAUTION

---

It is essential that all instructions in this manual be followed precisely to ensure proper operation of the equipment.

---

## Instruction Manual

---

# NOTICE

The content of this document is the intellectual property of Kistler-Morse. Any reproduction or translation of this document without the written authorization of a Kistler-Morse corporate officer is prohibited.

---

## SAFETY PRECAUTIONS

- ◆ **User's Responsibility for Safety:**

It is the user's responsibility to select a technology that is appropriate for the application, install it properly, perform tests of the installed system, and maintain all components. The failure to do so could result in property damage or serious injury.
- ◆ **Proper Installation and Handling:**

Because this is an electrically operated device, only properly-trained staff should install and/or repair this product. Use a proper sealant with all installations. *Note: Always install the 2" Viton gasket with the ULT. The G threaded version of the ULT will not seal unless the gasket is installed properly.* Never overtighten the transmitter within the fitting. Always check for leaks prior to system start-up.
- ◆ **Wiring and Electrical:**

A supply voltage of 12-32 VDC is used to power the transmitter. The sensor systems should never exceed a maximum of 32 VDC. Electrical wiring of the sensor should be performed in accordance with all applicable national, state, and local codes.
- ◆ **Temperature and Pressure:**

This sensor is designed for use in application temperatures from -40 °F (-40 °C) to 140 °F (60 °C), and for use at pressures up to 30 psi (2 bar) @ 77°F (25 °C), derated @ 1.667 psi (.113 bar) per degree above 77°F (25 °C.)
- ◆ **Material Compatibility:**

The continuous ultrasonic level transmitter is made of two materials. The enclosure is of Polypropylene (PP) and the transducer is made of Polyvinylidene (PVDF). Make sure that the model which you have selected is chemically compatible with the application liquids and vapors. While the transmitter housing is liquid-resistant when installed properly, it is not designed to be immersed. It should be mounted in such a way that it does not normally come into contact with fluid.
- ◆ **Flammable, Explosive, and Hazardous Applications:**

This sensor is rated for use in hazardous locations. Refer to the Certificate of Compliance for all applicable intrinsically safe ratings and entity parameters for this sensor. Refer to the National Electric Code (NEC) for all applicable installation requirements in hazardous locations.
- ◆ **Make a Fail-Safe System:**

Design a fail-safe system that accommodates the possibility of transmitter or power failure. In critical applications, it is recommended to use redundant backup systems and alarms in addition to the primary system.

# Table of Contents

|  |            |
|--|------------|
| <b>Introduction</b> .....  | <b>i</b>   |
| Description .....  | i          |
| About this manual .....  | i          |
| Manual Conventions .....   | i          |
| Contact Information .....  | ii         |
| Technical Service .....  | ii-iii     |
| <br>   |            |
| <b>Chapter 1. Pre-Installation of the I.S. Medium Range U.L.T.</b> ..... | <b>1-1</b> |
| Programming .....  | 1-1        |
| Wiring .....   | 1-2        |
| <br>   |            |
| <b>Chapter 2. Installation of the I.S. Medium Range U.L.T.</b> .....     | <b>2-1</b> |
| Mounting .....   | 2-1        |
| Minimum Range Setting .....  | 2-2        |
| Maximum Application Range .....  | 2-2        |
| Factory Settings .....   | 2-2        |
| Changing Display Units .....   | 2-3        |
| Beam Cone Data .....   | 2-3        |
| <br>   |            |
| <b>Appendix A: Product Specifications</b> .....                          | <b>A-1</b> |
| <br>   |            |
| <b>Appendix B: Definitions</b> .....                                     | <b>B-1</b> |
| <br>   |            |
| <b>Appendix C: Troubleshooting</b> .....                                 | <b>C-1</b> |



---

# Introduction

*This chapter describes the organization, manual conventions, and provides contact and technical service information.*

---

## Description

An ultrasonic sound wave is pulsed two times per second from the base of the transducer. The sound wave reflects against the process medium below and returns to the transducer. The microprocessor based electronics measure the time of flight between the sound generation and receipt, and translates this figure into the distance between the transmitter and process medium below.

This manual describes the installation of the Intrinsically-Safe Medium Range Ultrasonic Level Transmitter (I.S. Medium Range ULT). It includes instructions for installation, product specifications, and troubleshooting notes.

Contact Kistler-Morse at 1-800-426-9010 if you have any questions regarding the installation. Outside the USA and Canada, call 864-574-2763.

---

## About this manual

The chapters are organized in the following way:

Chapter 1:       Pre-Installation of the I.S. Medium Range ULT  
Chapter 2:       Installation of the I.S. Medium Range ULT

Appendix A through C include specifications, definitions, and troubleshooting.

---

## Manual Conventions

Three kinds of special explanations appear throughout the manual — *Warning, Caution and Note*. The format and significance of each is defined below:

 **WARNING**

Possible danger to people. Injury may result if this information is ignored.

 **CAUTION**

Possible risk to the product. The ULT or other equipment may be damaged if this information is ignored.

 **Note**

Contains additional information about a step or feature critical to the installation or operation of the ULT.

## Contact Information

You may reach Kistler-Morse headquarters at the following:

Mail: Kistler-Morse  
150 Venture Blvd.  
Spartanburg, South Carolina USA 29306

Telephone: 1-800-426-9010  
(864) 574-2763

Fax: (864) 574-8063

E-mail: sales@kistlermorse.com

Website: <http://www.kistlermorse.com>

---

## Technical Service

A complete, unabridged copy of our product warranty is available upon request from KM. A summary of the warranty, *subject to the terms and conditions listed fully in the warranty*, follows:

KM warrants the equipment to be free from defects in material and workmanship for two years from date of shipment to original user. KM will replace or repair, at our option, any part found to be defective. Buyer must return any part claimed defective to KM, transportation prepaid.

KM maintains a fully trained staff of field service personnel who are capable of providing you with complete product assistance.

---

### Phone Consultation

Our Customer Service staff provides the following services by telephone, via our regular and toll free number (toll free in U.S.A. and Canada only):

- Technical, application, and troubleshooting assistance
- Spare parts assistance
- Warranty (replacement) assistance

---

### On-Site Consultation

KM's Field Service staff can provide additional services at your request. Contact KM for rate and scheduling information for the following services:

- Technical, application, startup, and troubleshooting assistance on-site
- Training on-site or at our corporate office
- Service calls
- Equipment updates to our latest configuration

General descriptions of some of these standard services follow. Of course, if your service needs vary from those described, we are available to discuss them with you.

---

### Installation, Startup Assistance, and On-Site Training

The system will be powered up and checked for proper electrical operation. Recommendations for the optimal performance of the system will be provided.

---

### Troubleshooting

KM will troubleshoot systems for mechanical, electrical, calibration, and wiring errors. Normal component repairs will be made and wiring errors will be corrected, including replacement of non-repairable printed circuit boards.

---

### Service Calls

KM will perform on-site repair/replacement services.

---

### Return Material Authorization

If a part needs to be sent to the factory for repair, contact KM's corporate office and request a Return Material Authorization (RMA) number. The RMA number identifies the part and the owner and must be included with the part when it is shipped to the factory.

# Chapter 1:

## Pre-Installation of the I.S. Medium Range U.L.T.

*This chapter describes the pre-installation programming and wiring for the I.S. Medium Range ULT.*

### Programming



*Note: For definitions of the following programming functions, see Appendix B.*

Open the top cap to complete the following instructions.

#### EC4:

1. Hold [MENU] key until EC4 appears in display.
2. Release [MENU] key and wait until a value appears. This value is the current measured level value.
3. If this is acceptable, press [SET] to lock the value as the new EC4 set point. If not, press either the [▲] or [▼] keys once and the old setting for the EC4 will appear.
4. From here, use the [▲] or [▼] keys to raise or lower the value to the desired value.
5. Press the [SET] key to enter this value as the new EC4 set point.

#### EC20:

1. Hold [MENU] key until EC20 appears in display.
2. Release [MENU] key and wait until a value appears. This value is the current measured level value.
3. If this is acceptable, press [SET] to lock the value as the new EC20 set point. If not, press either the [▲] or [▼] keys once and the old setting for the EC20 will appear.
4. From here, use the [▲] and [▼] keys to raise or lower the value to the desired value.
5. Press the [SET] key to enter this value as the new EC20 set point.

#### SAF1/SAF2/SAF3:

1. Hold [MENU] key until SAF1, SAF2 or SAF3 appears in the display.
2. Release [MENU] key and hold [SET] key to toggle between SAF1, SAF2 or SAF3.
3. When desired setting is reached, release [SET] key. The last displayed setting will be locked into memory. To change, start again at step 1.

#### FAST/SLOW:

1. Hold [MENU] key until FAST or SLOW appears in the display.
2. Release [MENU] key and hold [SET] key to toggle between FAST and SLOW.
3. When desired setting is reached, release [SET] key. The last displayed setting will be locked into memory. To change, start again at step 1.

**ALIN:**

1. Hold [MENU] key until ALIN appears in the display.
2. Continue to hold [MENU] key until OFF appears in the display.
3. Release [MENU] key and hold [SET] key to toggle from OFF to ON.
4. Release [SET] key. The sensor is now in ALIN mode.
5. To exit ALIN mode, repeat steps 1-4 changing from ON to OFF.

**MAXR:**

1. Hold [MENU] key until MAXR appears in the display.
2. Continue to hold [MENU] key until a value appears in the display. This value is the current MAXR setting.
3. If this is acceptable, press [SET] to lock the value as the MAXR setting. If not, use the [▲] or [▼] keys to raise or lower the value to the desired setting.
4. Press the [SET] key to enter this value as the new MAXR setting.

**MINR:**

1. Hold [MENU] key until MINR appears in the display.
2. Continue to hold [MENU] key until a value appears in the display. This value is the current MINR setting.
3. If this is acceptable, press [SET] to lock the value as the MINR setting. If not, use the [▲] or [▼] keys to raise or lower the value to the desired value.
4. Press the [SET] key to enter this value as the new MINR setting.

**Wiring**

★ *Note: The ULT requires 12-32 VDC power with at least a 25mA supply in order to operate.*

1. Wiring to a *hydra-wave* Continuous Relay Controller:

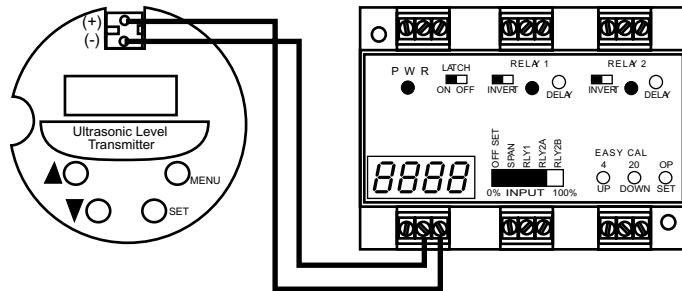

2. Wiring to a Two-Wire Loop Indicator:

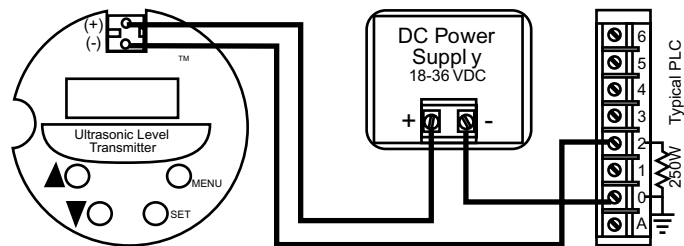

## Wiring: Hazardous Systems

The following diagrams are an overview of wiring the I.S. Medium Range ULT to various devices. Note that a barrier must be installed between the ULT and the device. The barrier must be located within the non-hazardous location.

Hazardous System Diagram

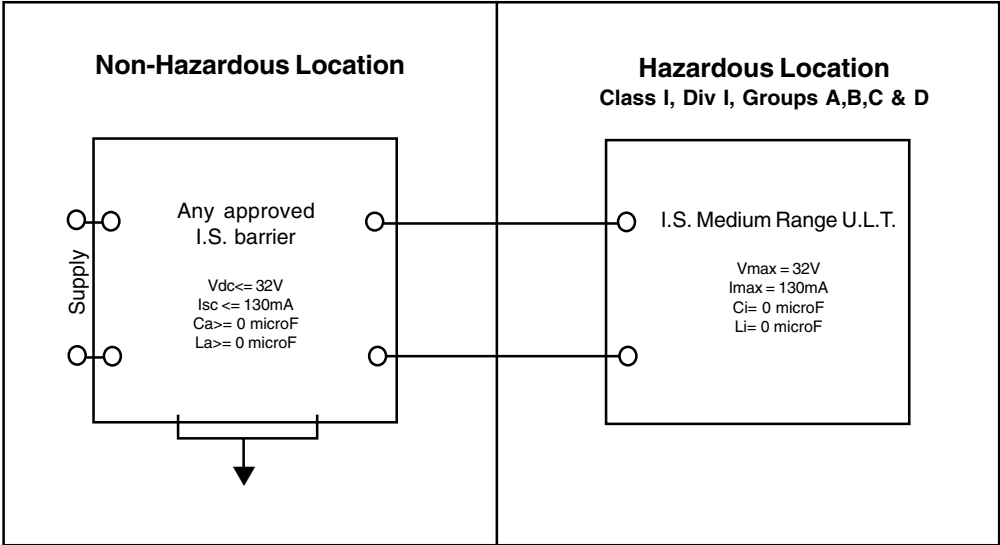

Wiring to a Continuous Relay Controller

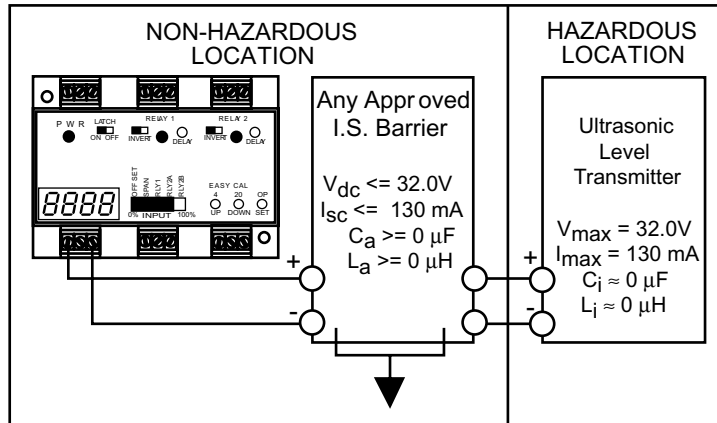

Wiring to a Two Loop Wire Indicator:

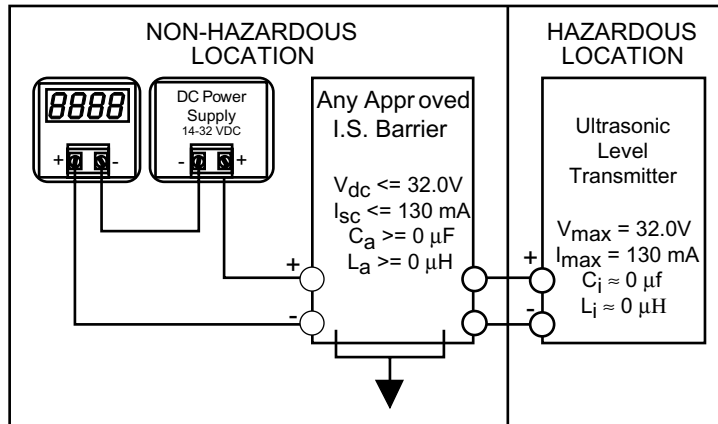

Wiring to a PLC:

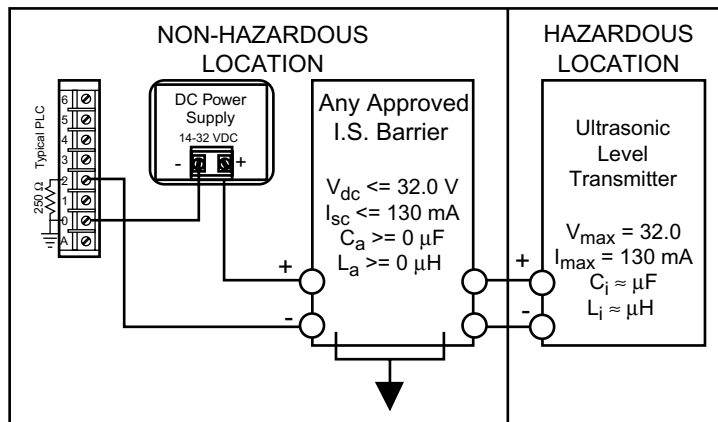

# Chapter 2: Installation of the I.S. Medium Range U.L.T.

*This chapter describes the installation procedures including the mounting and the factory settings.*

### Mounting:

Mounting the ULT properly is critical to operation. If the ULT is installed such that it is recessed in a fitting or flange, follow the criteria listed below. For an I.D. less than 3", do not recess the ULT more than 1" for best results. *The flange riser height is defined as the distance from the bottom of the transducer to the opening of the tank.*

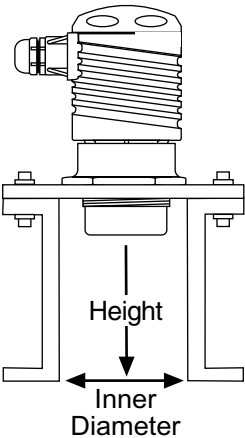

| <b>Flange Riser</b> |             |               |             |
|---------------------|-------------|---------------|-------------|
| <b>I.D.</b>         |             | <b>Height</b> |             |
| <i>(in.)</i>        | <i>(cm)</i> | <i>(in.)</i>  | <i>(cm)</i> |
| 3                   | 7.6         | 3             | 7.6         |
| 4                   | 10.2        | 7             | 17.8        |
| 5                   | 12.7        | 11            | 27.9        |
| 6                   | 15.2        | 15            | 38.1        |
| 7                   | 17.8        | 19            | 48.3        |
| 8                   | 20.3        | 26            | 66.0        |

### Positioning:

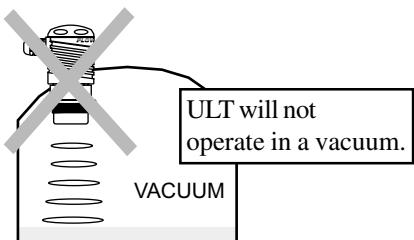
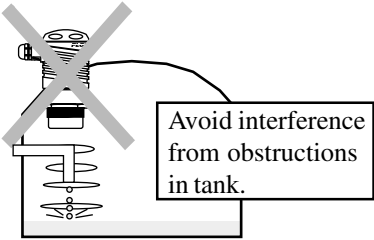
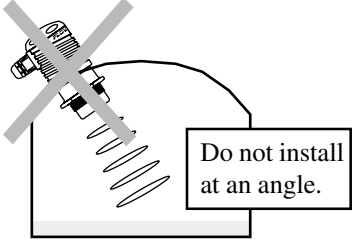
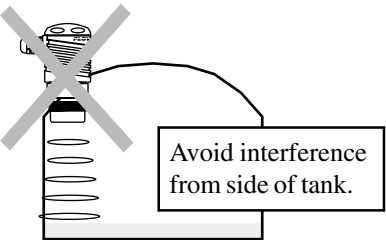

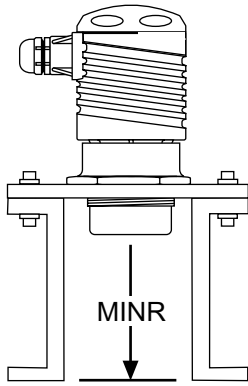

### Minimum Range (MINR) Setting:

If installing the ULT in a flange or any device which recesses the bottom of the transmitter, use the MINR setting. The minimum value for the MINR setting is the distance from the bottom of the transmitter to the end of the flange. Never set MINR to less than 6.0 inches.

### Maximum Application Range:

The maximum range of the ULT is 18 feet at 110 dB. Under less than ideal conditions, a number of factors can reduce the overall quality of signal return and shorten the accurate range of the transmitter. To determine the maximum application range of the product, follow the signal return formula against the echo attenuation graph below.

### Echo Attenuation Range Graph

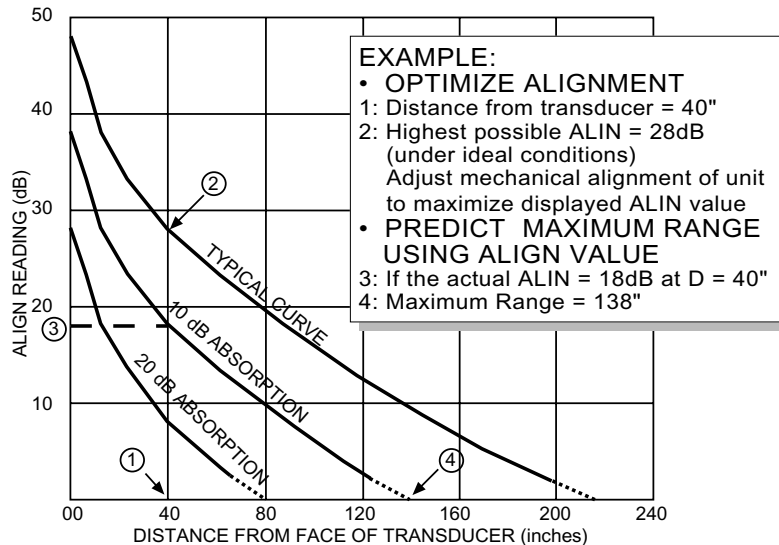

### Factory Settings:

The ULT is preset at the factory. When powering up the ULT the first time, the factory settings will be active. If at any time you need to return to these settings, remove power from the ULT and wait 10 seconds. Press the [Set] and [Menu] buttons simultaneously while powering up the ULT.

|           |                 |       |                 |
|-----------|-----------------|-------|-----------------|
| EC 4      | 216" (548.4 cm) | OFF   | OFF             |
| EC20      | 8" (20.3 cm)    | MAXR  | N/A             |
| SAF1/2/3  | SAF1            | value | 216" (548.4 cm) |
| Fast/Slow | FAST            | MINR  | N/A             |
| ALIN      | N/A             | value | 6" (15.2 cm)    |

---

**Changing Display Units:**

The ULT comes preset to measure in inches. To change the unit to display centimeters, remove power to the unit and wait 10 seconds. Press [▲] and [Set] simultaneously while powering up the sensor. It will now read in centimeters. To return to inches, remove power and wait 10 seconds. Press [▼] and [Set] simultaneously while powering up the ULT.

---

**Beam Cone Data:**

| Depth<br>(feet) | Radius<br>(inches) | Radius<br>(cm) |
|-----------------|--------------------|----------------|
| 1               | 1.2                | 3.1            |
| 2               | 2.1                | 5.2            |
| 3               | 2.9                | 7.3            |
| 4               | 3.7                | 9.5            |
| 5               | 4.6                | 11.6           |
| 6               | 5.4                | 13.7           |
| 7               | 6.2                | 15.9           |
| 8               | 7.1                | 18.0           |
| 9               | 7.9                | 20.1           |
| 10              | 8.8                | 22.3           |
| 11              | 9.6                | 24.4           |
| 12              | 10.4               | 26.5           |
| 13              | 11.3               | 28.7           |
| 14              | 12.1               | 30.8           |
| 15              | 13.0               | 32.9           |
| 16              | 13.8               | 35.1           |
| 17              | 14.6               | 37.2           |
| 18              | 15.5               | 39.3           |

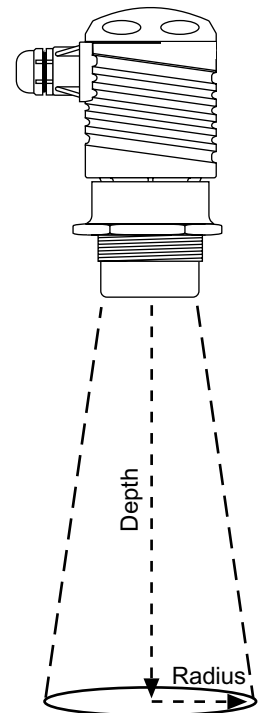

# Appendix A: Product Specifications

|                               |                      |  |
|-------------------------------|----------------------|--|
| <b>Accuracy:</b>              | Range:               | 0.5 to 18 feet (15 cm to 5.4 m)  |
|                               | Accuracy:            | ± 0.25% of span (air)  |
|                               | Resolution:          | 0.125" (3 mm)  |
| <b>Rate:</b>                  | Frequency:           | 50 kHz   |
|                               | Pulse rate:          | 2 pulses per second  |
| <b>Beam:</b>                  | Beam width:          | 8° conical   |
|                               | Dead Band:           | 0.5' (15 cm) minimum   |
|                               | Blocking distance:   | 0.5 to 18 feet (15 cm to 5.4 m)  |
| <b>Display:</b>               | Type:                | 4 segment LED  |
|                               | Display units:       | Inches (cm)  |
| <b>Memory:</b>                |                      | Non-volatile   |
| <b>Electrical:</b>            | Supply voltage:      | 12-32 VDC  |
|                               | Max Loop Resistance: | 900 Ohms @ 32 VDC (see below)  |
|                               | Signal output:       | 4-20 mA, 14-32 VDC (see below)   |
|                               | Signal invert:       | 4-20 mA / 20-4 mA  |
|                               | Calibration:         | Push button  |
| <b>Fail-safe diagnostics:</b> |                      | Reverts to 4 mA, 22 mA or remains constant   |
| <b>Temperature:</b>           | Temperature rating:  | F: -40° to 140°<br>C: -40° to 60°  |
|                               | Temp. compensation:  | Automatic over entire range  |
| <b>Pressure:</b>              | Pressure rating:     | 30 psi (2 bar) @ 25 °C (77°F), derated @ 1.667 psi<br>(.113 bar) per degree above 25 °C (77°F) (see below) |
| <b>Physical:</b>              | Enclosure rating:    | NEMA 4X (IP65)   |
|                               | Enclosure material:  | Polypropylene (PP), U.L. 94VO  |
|                               | Transducer material: | Polyvinylidene Fluoride (PVDF)   |
|                               | Mounting threads:    | 2" NPT (2" G)  |
|                               | Mounting gasket:     | Viton (2") metric only   |
|                               | Conduit connection:  | 1/2" NPT (1/2" BSP)  |
| <b>CE compliance:</b>         |                      | EN 50082-2 immunity<br>EN 55011 emission   |
| <b>CSA certificate:</b>       |                      | LR79326-10   |



LR79326-10

NRTL/C

Intrinsically Safe/

Securete Intrinseque

Exia

For use in

Hazardous Locations:

Class I, Groups A, B, C &amp; D

Class II, Groups E, F &amp; G

Class III

Temperature Code: T3C

Intrinsically Safe when used with  
an approved I.S. barrier. Entity  
Parameters $V_{max}$  = 32.0 VDC $I_{max}$  = 130 mA $C_i$  = 0 mF $L_i$  = 0 mH

## Warning

The I.S. Medium Range ULT is a loop powered device. The load should never exceed 900 Ohms. When installing the ULT, never tighten the transmitter from the body. Always use the wrench flat located above the threads.

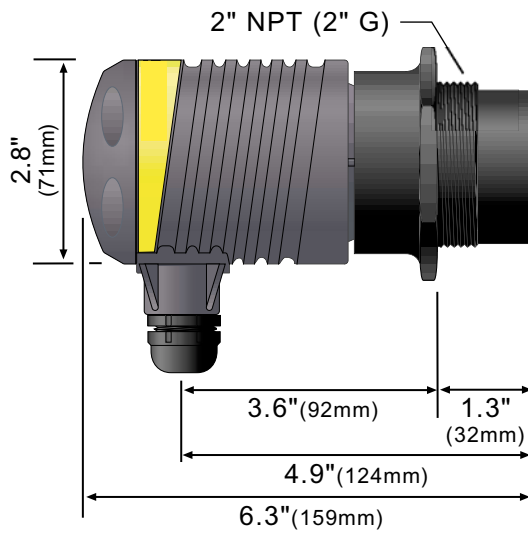
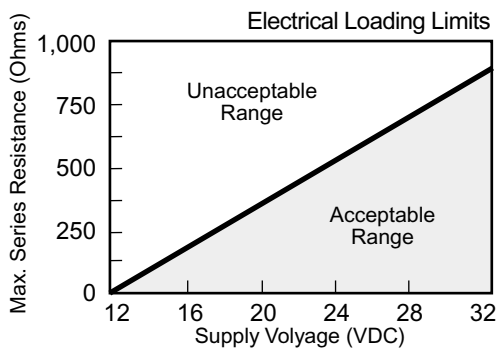
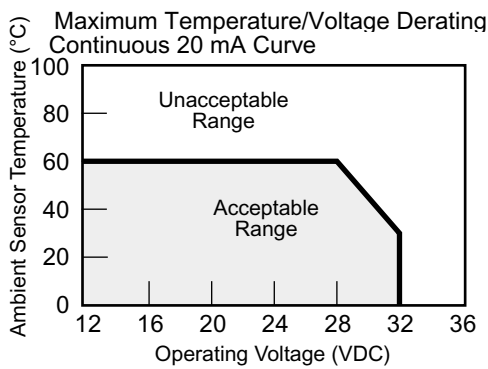
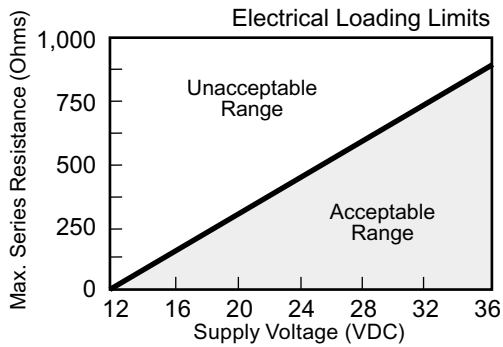
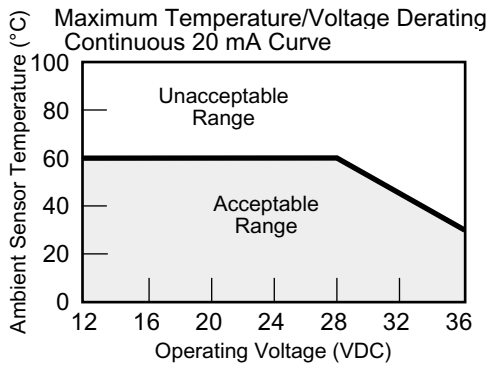
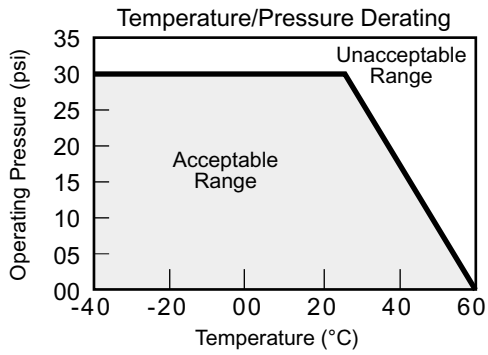

# Appendix B: Definitions

*This section contains definitions for programming functions.*

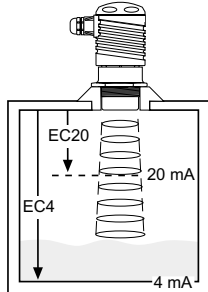
**EC4**

The 4 mA setting for the I.S. Medium Range ULT. The EC4 is the distance from the bottom of the ULT to the 4 mA set point. This setting is measured in either inches or centimeters on the display.

**EC20**

The 20 mA setting for the I.S. Medium Range ULT. The EC20 is the distance from the bottom of the ULT to the 20 mA set point. This setting is measured in either inches or centimeters on the display.

**SAF1/SAF2/SAF3**

Fail-Safe setting for the ULT. Use the SAF settings to determine a fail-safe mode for the current signal. When [SAF1] is set, the current will increase to 22 mA if the signal becomes LOST. When [SAF2] is set, the current will decrease to 4 mA if the signal becomes LOST. When [SAF3] is set, the current will remain constant if the signal becomes LOST.

**FAST/SLOW**

Setting for echo averaging on the ULT. [FAST] is the typical setting for the ULT to operate. [SLOW] is designed to help dampen out effects caused by severe turbulence. In the [FAST] mode, it will average 2 signal responses per second and update every second. In the [SLOW] mode, it will average signal returns over the preceding 10 seconds. When used with [SAF 1/2/3], the time for the current to default is 30 seconds for [FAST] mode and 2.5 minutes for [SLOW] mode.

**ALIN**

Indicates that the unit is in the Alignment mode. Display will show the return signal strength in dB's. Used as an indicator for mechanical alignment of the ULT and/or signal attenuation. Typical readings range between 2 and 60 dB's. For optimum alignment, first energize the unit and receive a valid return signal. Then select the ALIN mode and adjust the ULT until the value is maximized.

**ON/OFF**

Actual setting for ALIN mode. The ALIN mode must be turned [OFF] when alignment is completed. This mode will not automatically default back to [LEVL].

**MAXR**

Used as an indication for [MAXR] or maximum range. The MAXR sets the maximum tank height and will filter out all returns greater than this value.

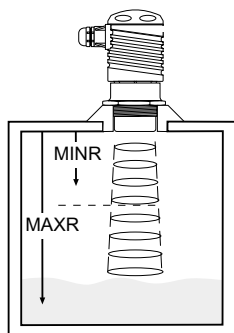
**(value)**

Actual MAXR setting. The maximum distance is 216.0 inches.

**MINR**

Used as an indication for [MINR] or the minimum range. The MINR value is the deadband closest to the transducer face where no signal will be generated. The MINR sets the minimum distance between the liquid and the transducer.

**(value)**

Actual MINR setting. The minimum distance is 6.0 inches.

# Appendix C: Troubleshooting

*This section includes troubleshooting notes for the I.S. Medium Range U.L.T.*

## Lost Signal:

A reading of LOST in the display indicates the transmitter is not receiving a valid return signal. If LOST appears, please check the following troubleshooting items:

1. Beam cone interferences such as the side wall, ladders, seams, rungs or pipes within the ULT's beam cone.
2. Proper installation such that the ULT is installed level and free from interference from the installation fitting or flange.
3. Sufficient power being supplied to the ULT. It requires 12-32 VDC power with a minimum supply of 25 mA.
4. Proper programming of the MAXR and MINR function. For best results, set the MAXR function as the distance from the bottom of the tank to the bottom of the transmitter. Also set the MINR distance above the highest level in the tank. Do not set the MINR to less than 6 inches.
5. Make sure that the transmitter is not installed at an angle. Even a 5 degree offset can reduce the signal return strength greatly.

## Other Hints:

Current must change with changes in level.

*Example: For the illustration below, as level increases, the current output will increase and as the level decreases, the current output will decrease. If the output of the ULT is always reading 4 mA or 20 mA, check the input values for the ULT.*

