

Junction Box Manual

97-1076-01
REV. A

NOTE

It is essential that all instructions in this manual be followed precisely to ensure proper operation of the equipment.

97-1076-01
REV. A
October 1995

Table of Contents

THE NEW KISTLER-MORSE JUNCTION BOX	SB-1
FEATURES	SB-1
MOUNTING THE JUNCTION BOXES . .	SB-2
WIRING THE SENSORS TO THE JUNCTION BOXES	SB-2
WIRING THE JUNCTION BOXES	SB-3
Wiring the Domestic Junction Boxes Together and to the Electronics	SB-3
Wiring the International Junction Boxes Together and to the Electronics	SB-4

Index of Figures

Figure SB-1. The New Kistler-Morse Junction Box SB-1

Figure SB-2. Fittings on the International Version Junction Box. SB-1

Figure SB-3. Fittings on the Domestic Version Junction Box . . SB-1

Figure SB-4. Mounting Hole Dimensions of New Junction Box . SB-2

Figure SB-5. Mounting Hole Dimensions of Old Junction Box . SB-2

*Figure SB-6. Inserting the Sensor Cable Through the
Watertight Fitting* SB-2

Figure SB-7. Wiring the Domestic Junction Boxes Together . . SB-3

Index of Tables

*Table SB-1. Plugs and Fittings that are Shipped with the
Junction Boxes* SB-1

*Table SB-2. New Junction Box Model Numbers
Cross-Referenced with Applications and Old Part Numbers . .* SB-4

THE NEW KISTLER-MORSE JUNCTION BOX

Kistler-Morse has developed a new junction box that will be used with Microcell Bolt-On and Direct Support products (Figure SB-1). The new j-box is made of Noryl 731 plastic and has two versions to support domestic and international applications. Heyco cable fittings (or equivalent) are provided with each junction box as well as threaded plugs for closing off unused cable entry holes. Figure SB-2 shows a JB2 international junction box equipped with four sensor cable fittings and two interconnect cable fittings. Figure SB-3 shows a JB1 domestic junction box equipped with four sensor cable fittings. A conduit fitting for the conduit entry hole must be customer supplied. Table SB-1 describes the types and quantities of plugs and fittings that are shipped with the junction boxes.

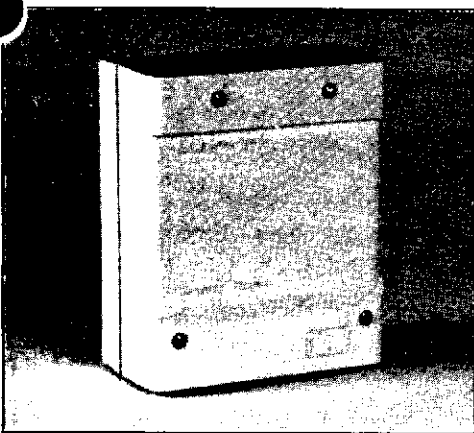

Figure SB-1. The New Kistler-Morse Junction Box.

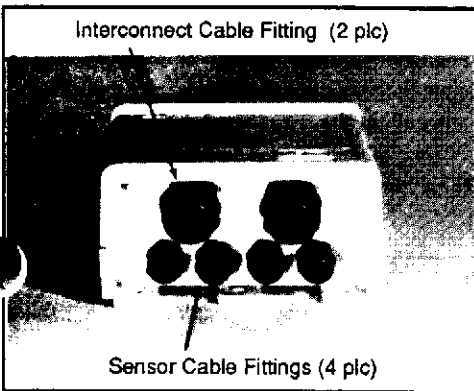

Figure SB-2. Fittings on the International Version Junction Box.

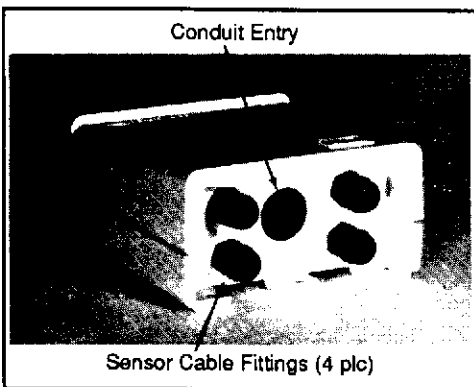

Figure SB-3. Fittings on the Domestic Version Junction Box.

Junction Box	Sensor Cable		Interconnect Cable	
	Fittings	Plugs	Fittings	Plugs
JB1 Junction Box When Shipped with Sensors	One for Each Sensor	4	NONE	NONE
JB1 Junction-Box When Shipped Separately	4	4	NONE	NONE
JB2 Junction Box When Shipped with Sensors	One for Each Sensor	4	2	1
JB2 Junction Box When Shipped Separately	4	4	2	1

Table SB-1. Plugs and Fittings that are Shipped with the Junction Boxes.

NOTE

Kistler-Morse recommends routing the interconnect cables from each of the domestic junction boxes and the electronics through 3/4-inch conduit and using a watertight 3/4-inch NPT conduit fitting. If conduit is not used, use a watertight cable fitting in the junction boxes and the electronics enclosure.

FEATURES

- Two interconnect cable entry options - one conduit-sized hole (JB1) for the domestic market and two holes with watertight strain relief fittings (JB2) for the international market and for nonconduit applications.
- Adjustable watertight strain relief fittings are provided for the sensor cables with plugs provided for unused sensor cable entry holes.
- New water seal design consists of knife-edge contact with a flat gasket between the cover and box resulting in high contact pressure to keep moisture out.
- All cable and conduit entry holes are in the bottom of the junction box to protect against water seepage.
- Overhanging apron protects the sensor lead and cable entry fittings from washdown splash.

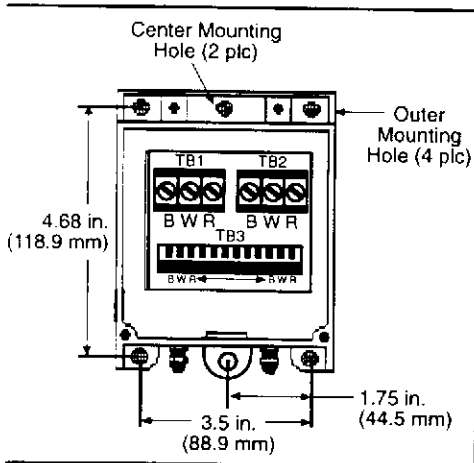

Figure SB-4. Mounting Hole Dimensions of New Junction Box.

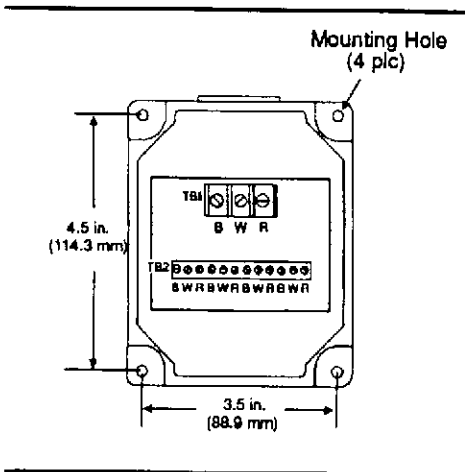

Figure SB-5. Mounting Hole Dimensions of Old Junction Box.

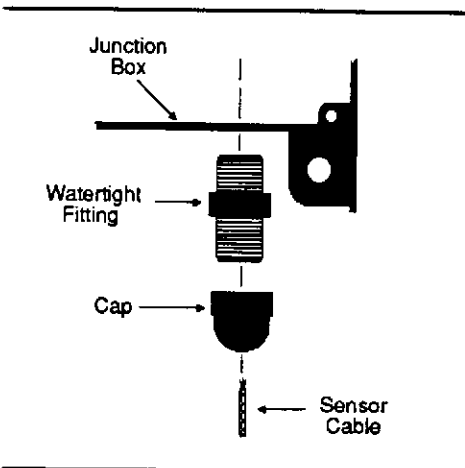

Figure SB-6. Inserting the Sensor Cable Through the Watertight Fitting.

- A wide apron shields the parting line between cover and box from impinging washdown spray.
- Internal cavity is larger for greater ease in connecting the sensor leads and the interconnect cable to the termination pcb.
- Raised mounting pads allow secure bolting of the junction box to an uneven surface.
- Two additional mounting pads are located on the vertical centerline for installation on curved surfaces such as pipe legs.
- Captive screws fasten the cover to the box so they cannot be lost when the cover is removed.

MOUNTING THE JUNCTION BOXES

The domestic and international junction boxes have identical mounting hole patterns. Use this procedure to mount either type.

1. Remove the cover of the junction box by loosening the four captive screws.
2. Hold the junction box on the support at the desired mounting location. Use a pencil to mark the four outer mounting holes on the support (Figure SB-4). If you are mounting the junction box on a pipe leg, use the two center mounting holes to mount the j-box. Figure SB-5 shows the old junction box to allow you to compare the old j-box mounting holes with the new.

NOTE

In Bolt-On sensor applications, the j-box must be at least 30 inches below the sensor(s) and the sensor cables must form a drip loop.

3. Set the j-box down. Drill and tap the holes with a #29 bit and a #8-32 tap.
4. Secure the junction box to the support with #8-32 screws and washers.

WIRING THE SENSORS TO THE JUNCTION BOXES

There are four small holes with watertight fittings for the sensor cables and one large hole for a customer-supplied conduit fitting in the bottom of the domestic version junction box (Figure SB-3). The international version junction box (which is also available domestically) has four small holes with watertight fittings and two larger holes with cable fittings (Figure SB-2). Although the hole configurations are different, the wiring of the sensors and the electronics to the two types of junction boxes are the same. Follow this procedure to wire sensors to either type of box.

1. Remove the cover of the junction box.
2. Unscrew the cap of the watertight fitting and thread the sensor cable through the cap and fitting as shown in Figure SB-6.
3. Screw the fitting into one of the four holes in the bottom of the junction box.

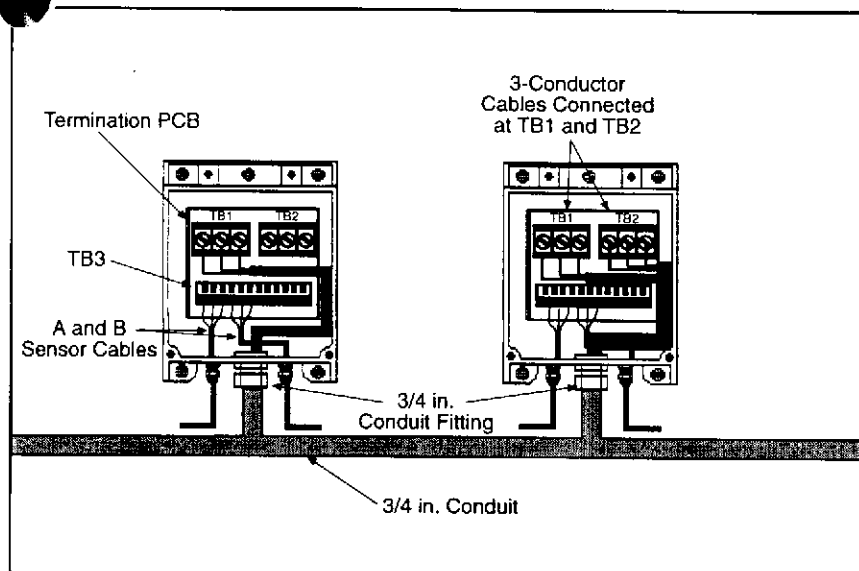

Figure SB-7. Wiring the Domestic Junction Boxes Together.

NOTE

When wiring Bolt-On Microcell sensors in a Rosette Tee configuration, be sure to follow the instructions in the Microcell Sensor Manual, P/N 97-10112-02.

4. The TB3 terminal block on the termination PCB (Figure SB-7) has 12 terminals that will accommodate four sensors (SENSOR A, SENSOR B, SENSOR C, SENSOR D). Locate the terminals labeled for the sensor you are wiring and secure the black wire of the sensor cable to the 'B' terminal, the white wire to the 'W' terminal, and the red wire to the 'R' terminal. Follow this code for all versions of junction box termination PCBs.
5. Take most of the slack out of the cable in the junction box, leaving a little for strain relief, and tighten the cap on the watertight fitting.

6. Perform Steps 1 through 5 for all of the sensors you are wiring to the junction box. Screw the factory provided plugs into the holes that are not being used.

WIRING THE JUNCTION BOXES

A shielded three-conductor cable is used to wire the junction boxes together and to the weighing system electronics. K-M recommends using Belden 8791 18-gauge cable or equivalent.

Wiring the Domestic Junction Boxes Together and to the Electronics

1. Install a watertight conduit fitting into the large hole on the bottom of the junction box (Figure SB-7). Kistler-Morse recommends using 3/4 inch conduit with a 3/4 inch NPT conduit fitting in each JB1 junction box.
2. Route the three-conductor cable through the fitting into the junction box. The cable must be supplied by the customer (Belden #8791 or equivalent).

NOTE

Ground the cable shield **ONLY** at the electronics.

3. Connect the black wire to the black terminal, white wire to the white terminal, and red wire to the red terminal on the TB1 or TB2 terminal block.

NOTE

All wire routed between junction boxes and the electronics must be continuous (no splices).

4. Remove excess cable slack from the junction box, leaving a little for strain relief.

5. Connect the conduit to the fitting and route the cable through the conduit to the next junction box (or to the electronics).
6. Use TB1 and TB2 as shown in Figure SB-7 to wire multiple junction boxes together.

Wiring the International Junction Boxes Together and to the Electronics

1. Install cable fittings in the holes in the bottom of the junction box (Figure SB-2). The last junction box in the loop needs a cable fitting in one hole and a factory-provided plug in the other hole.
2. Route the three-conductor cable through the fitting into the junction box. The cable must be supplied by the customer (Belden #8791 or equivalent).

NOTE

Ground the cable shield ONLY at the electronics.

3. Connect the black wire to the black terminal, white wire to the white terminal, and red wire to the red terminal on TB1 (and on TB2 when wiring multiple junction boxes together).

NOTE

All wire routed between junction boxes and the electronics must be continuous (no splices).

4. Remove excess cable slack from the junction box, leaving a little for strain relief.
5. Tighten the cable fitting(s) snugly around the cable(s) to create a watertight seal.
6. Route the cable to the next junction box (or to the electronics). Repeat this procedure to wire each junction box in the loop and to wire the electronics.

New Junction Box Model No.	Application	Old Part Number
JB11-LS and JB21-LS	Load Stand transducer, original manufacture	-
JB12-H and JB22-H	Horizontal shear beam applications	61-4015-02
JB13-WFM/R and JB23-WFM/R	Rosette sensor array on skirted silos; also used with Weighflow Monitor Weighframes (single-idler and dual-idler), as well as on Conveyor Monitor applications	61-4015-02 (Rosette) 61-4015-05 (Weighframe)
JB14-LSS and JB24-LSS	Load Stand spare, after-market sale	-
JB15-BO/LD and JB25-BO/LD	Bolt-On vertical leg applications; also used with Load Disc transducer	61-4015-04
JB16-TB and JB26-TB	Terminal block (no termination PCB), presently this is a 4-position terminal block	61-4015-03
JB17-POT and JB27-POT	Adjustable potentiometer on the termination PCB to tune a vertical leg Bolt-On System (balance the leg sensor signal versus the brace sensor signal)	Custom P/N Only (1361-631)

NOTE: JB1 prefix refers to the domestic version junction box. JB2 prefix refers to the international version junction box.

Table SB-2. New Junction Box Model Numbers Cross-Referenced with Applications and Old Part Numbers.